



2025 RULEBOOK



U.S. LEGEND CARS
INTERNATIONAL



INEX

5245 NC Highway 49 South
Harrisburg, NC 28075
704-455-3906

www.inexseries.com

Scott Reinhardt
INEX General Manager, Competition Director &
Technical Director

704-512-0711

sreinhardt@uslegendcars.com

Brittany Beck
INEX Events Manager
704-455-3906

bbeck@uslegendcars.com

Josh Roller
Communications Manager

704-247-5370

jroller@uslegendcars.com



5245 NC Highway 49 South
Harrisburg, NC 28075
704-455-3896
www.uslegendcars.com

Jessica Fickenscher
Executive Vice President

G. E. Chapman
Vice President of Racing Operations &
Manufacturing US Legend Cars & INEX
704-455-3896
gechapman@uslegendcars.com

Richard Burke
Senior Vice President of Finance
rburke@uslegendcars.com



US Legend Cars Engine Shop
5245 NC Highway 49 South
Harrisburg, NC 28075

Chad Honeycutt
Engine Shop Manager
704-455-6637
chadh@uslegendcars.com

TABLE OF CONTENTS

5	Definitions of Terms
7	INEX Mission Statement
8	Preface to the Rules
9	Specification Exceptions
9	Bulletins
10	Inclement Weather/Postponement and/or Event Cancellation
10	INEX Membership Requirements
10	10 INEX Memberships (Member and Associates)
11	11 Membership requirements under 18
11	11 Event Release and Indemnity Agreements
12	12 Membership Violations
12	Medical Attention/Injuries
12	12 Injuries Reporting
13	Event Insurance Coverage
13	13 Insurance Provided for Members/Associates
14	14 Insurance Claim Submission Process
14	Controlled Substance Abuse Policy
15	Drivers Ability Responsibilities
15	Advertising and Promotion Release
16	Technical Inspection Process
16	INEX Officials
16	INEX Technical Inspector
17	Interpretation and Application of all Rules
17	Car Entry for Competition
18	Enforcement of Specification Rules/Measuring Equipment
18	18 Ineligible Component(s) after Competition
18	18 New Enforcement Procedures & Equipment
19	Race Director
19	Event Race Procedures & Lineups (Suggested)
19	19 Suggested Flag Usage
21	21 Time Limit of Race
21	21 Scoring
21	21 Original Starts and Restarts
22	22 Suggested Race Procedure
22	22 Caution Periods
23	Conduct & Pit Area Rules
23	23 Participant Conduct
24	24 2-2-2 Policy
24	Penalties for Rule Infractions
26	Dispute of a Decision
26	Appeals Process (for Penalties)
28	Filing a Complaint
28	Accounts Receivables
29	Driver Divisional Structures
29	29 LEGEND CARS
	Legend Cars Division
30	30 Divisional (class) Change/ LEGEND

- 31 **BANDOLERO CARS**
 - Bandolero Cars Divisions
 - 31 Divisional (class) Change/**BANDOLERO**
- 31 Points System
 - 31 Points Season
 - 34 Points Schedule
 - 35 Championships
 - 35 National Event track testing/rentals
- 38 Protests
 - 39 Time of the Protest
 - 39 Verification of Protest
 - 39 When the Protest Finds a Legal Component
 - 39 When the Protest Finds an Illegal Component
 - 40 Refusal of a Protest
 - 40 NON-Acceptance of a Protest
 - 41 Protest Fee Schedule/**LEGEND**
 - 42 Protest Fee Schedule/**BANDOLERO**
- 43 COMPONENT PROTEST CARD
- 45 Personal (Driver) Safety Equipment
 - 47 Additional Personal Safety Equipment
- 49 FUEL REQUIREMENTS
 - 49 **LEGEND CARS**
 - 49 **BANDOLERO CARS**
 - 50 Fuel Additives
 - 50 Penalty for Fuel Rule Violations
- 51 **LEGEND CARS SPECIFICATIONS**
 - 51 Specification Expectation
 - 51 Frames, Body and Suspension Components
- 76 **LEGEND CARS** Engines Specifications
 - 76 Specification Expectation
 - 77 1250 & 1219 Yamaha Engines
 - 77 FJ1200 & XJR1200 Yamaha Engines
- 83 **BANDOLERO CARS SPECIFICATIONS**
 - 83 Specification Expectation
 - 83 Frames, Body and Suspension Components
- 97 **BANDOLERO CARS** Engines Specifications
 - 97 Specification Expectation
 - 97 Briggs & Stratton Vanguard Engine
- 103 Code of Conduct & Social Media Policy
- 107 End Notes

DEFINITION OF TERMS

Aftermarket - Parts, components and sub-assemblies produced by INEX approved manufacturer(s) other than original equipment manufacturer USLCl. Aftermarket parts must meet INEX specifications, unless otherwise noted in the INEX Rulebook.

Associate Member – A member that has the legal responsibility and representation of a minor aged Driver. The Associate Member is a parent or legally appointed guardian of the Driver. The Associate Member should be present during all post-race inspections, protests or other determinations that effect the finishing position of the Driver.

Authorized USLCl Dealer Network - The approved dealer and distributor of USLCl, cars, parts, and components. The list of the dealer network is maintained on the USLCl website.

WWW.USLEGENDCARS.COM

Bulletin-An amendment to the INEX rules, produced and distributed by INEX Headquarters

Competition/Race - A motorsports contest in which an INEX Driver participates and which is of a competitive nature or is given a competitive nature by the publication of results and part of an INEX Sanctioned Event or INEX Event. Examples are Practice, Qualifying, Qualifying and/or Heat Races and Race.

Driver – An INEX member, classified by age or experience to drive the racecar. Driver under the age of majority are permitted to have (and encouraged) assistance in their behalf from their Associate Member present. The Associate Member should be present during all post-race inspections, protests or other determinations that effect the finishing position of the Driver. A Driver earns awards, points and is responsible for the same. The Driver will be assessed penalties for Technical violations determined by INEX with-in their racecar. The Driver may be assessed penalties for behavioral violations determined by INEX of their crew members.

Disqualification -The forfeiture of all awards, prizes and points earned for and prior to the infraction during the date(s) of the Event.

E.I.R.I.-Except in rare incidences.

Event -An entire program of on-track, INEX Sanctioned Competition(s) or Race(s), including Practice, Qualifying or Qualifying Race(s) and/or Heat Races. A single Event can be conducted over several days and include associated off-track activities including Inspection (pre & post) and Registration.

INEX -The Sanctioning body for Legend Cars Racing. Develops interprets and enforces the specification rules for all Legend Cars and Bandolero Cars Events worldwide. INEX works with Track Promoters to schedule, promote, inspect car(s), and manage Events.

INEX Headquarters – INEX Headquarters are located at
5245 N.C. 49 South, Harrisburg, N.C. 28075
Telephone (704) 455-3906

INEX Member - A person that has submitted a membership application and been issued an INEX Membership number. The INEX Member must remain in good standing with INEX and have a valid membership.

Local Track Rules - Rules and procedures established to conduct Legend Cars and/or Bandolero Cars Races, printed, distributed, and enforced by the Promotor/host Track of an Event.

Participant -A Driver, competitor, mechanic, member, Associate Member, pitman, Track Official or employee bearing assigned pit passes duly and officially issued by the Track conducting an INEX Sanctioned Event.

Penalty -Any condition imposed on a participant for violation (failure to act in accordance) with the rules found in this rulebook. INEX in its sole discretion may imposed additional penalties based upon violation(s) of an Event. A Penalty is a violation of a Technical specification, a Procedural or behavioral violation.

Promoter -The person or body controlling a facility where Events are organized, promoted, and conducted. The Promoter is responsible for determining and enforcing all procedural and technical rules for their Event.

Qualifying -The format used to determine starting positions in Race including a timed session, Heat or Qualifying Race(s).

Sanction or Sanctioned Event -The authority granted by INEX to organize and conduct a Legend Cars and/or Bandolero Cars Competition/Event and use the INEX, Legend Cars, and/or Bandolero Cars name and logo.

Stock or Original Equipment Manufacturer/OEM - *USLCI is the exclusive OEM of INEX. Stock or OEM are Car, parts, components, assemblies or sub-assemblies as delivered new from USLCI maintaining specifications, manufactured tolerances, and standards without modification of the produced or delivered component without exception.*

Note: To assist participants throughout the Rulebook, these parts and components that must remain Stock as manufactured and delivered are written in an Italic font for identification ease.

Track Official - Persons provided by the Promoter to officiate as an independent agent or employee of the Promoter. Track Officials are not employed by INEX.

USLCI -U S Legend Cars International - Sole manufacturer of the Legend Cars and Bandolero Cars.

USLCI Engine Shop -The only INEX approved engine shop that is authorized to repair / certify an INEX Sealed engine.

Every Event which uses the name Legend Cars, Bandolero Cars and/or INEX or any likeness to the name or logo must be formally Sanctioned by INEX, Corp.

Unauthorized use of the name by Events or people will subject the user to legal action.

Mission Statement of the INEX Series:

Legend Cars and Bandolero Cars are worldwide Sanctioned by INEX and manufactured by USLCI to provide a fun and affordable racing opportunity in which anyone (experienced and inexperienced) can compete. This series is intended to fight the high costs involved in racing, and the rules are enforced to ensure fair Competition and cost control. The technical inspections will be fair and consistent without prejudice toward any Drivers.

PREFACE TO THE INEX RULES:

(Please Read Very Carefully and Understand)

IT IS THE RESPONSIBILITY OF EACH COMPETITOR TO READ AND UNDERSTAND THE RULEBOOK AND THE APPLICATION OF THESE RULES.

If there is a disagreement or dispute regarding the meaning or application of these rules, the interpretation and/or application of the local Track Officials shall prevail. Appeals may be considered by INEX Headquarters.

The rules and regulations set forth herein are designed to provide orderly conduct for racing Events and to establish minimum acceptable standards and requirements for such Events. These rules and regulations shall govern the conditions of all INEX Sanctioned Events, unless otherwise noted. All Competitors and Promoters are required to comply with these rules.

No express or implied warranty of safety shall result from publication of, or compliance with these rules, regulations, and standards. They are intended as a guide for the conduct of the sport and are in no way a guarantee against injury or death to Competitors, participants, spectators, or others. If a Driver should be seriously or fatally injured, **INEX reserves the right to impound the car for review and evaluation and may exercise this right at any time.**

No pretense is made for having designed a foolproof set of rules and regulations. The spirit and intent of the rules is the standard by which INEX Sanctioned racing Event is guided. Event INEX Technical Inspector(s) are authorized to determine if an equipment modification not specifically listed in this rulebook, is an attempt to circumvent these rules in any manner. Track Officials may disqualify an entry in violation of the spirit and intent of these rules. It is impossible to anticipate every potential circumstance, an INEX Technical Inspector or Track Official shall have the right to initiate action correcting a hazardous condition or a condition not in compliance with the spirit and intent of these regulations. Decisions are to be based on common sense, consistency, impartiality, and fair play. Continuous developments in racing may necessitate changes that we cannot anticipate at the time the rules are developed and published.

INEX members, Associate Members and participants fully understand that operation of a LEGEND CAR or BANDOLERO CAR exposes them to risks of DEATH, or SERIOUS BODILY INJURY. The INEX members, Associate Members and participants voluntarily assume these risks. In the case of a minor Competitor the parent or guardian accepts these responsibilities.

In consideration of acceptance by INEX of the membership application and payment of membership fees, the applicant agrees to abide by all rules, regulations, and decisions of INEX, as to conduct and mechanical specifications, as now published in this INEX Rulebook, or hereafter amended. INEX reserves the right to alter or amend these rules and/or regulations at any time in the interests of safety, cost control and/or fair Competition. **The interpretation of these rules is determined and solely applied by INEX. INEX Sanctioned Tracks will assist INEX in the application of these rules.**

SPECIFICATION EXCEPTIONS:

If the rulebook does not specifically state that a change/modification/addition or removal of component(s) is permitted, then a Competitor must consider that the change/modification/addition or removal is illegal. Any question(s) about the legality of a change or modification not covered in the rulebook must be submitted to, reviewed, and answered by the INEX Technical Director in writing and that decision is final. The cars, engines and components are designed to remain in the Stock original specification form as they were purchased "NEW" from USLCl unless specifically listed in this rulebook.

BULLETINS:

Any rules updates or safety Bulletins issued by INEX or USLCl after January 1, 2025, for the purpose of implementing, interpreting, or enforcing these rules will be deemed as part of and will supersede these rules. All personnel or Track representatives are required to enforce these rules. The rule amendments or safety Bulletins will only appear on INEX letterhead and posted at www.INEXseries.com or www.USLegendCars.com. INEX will distribute to all INEX Technical Inspectors, Officials, and Tracks.

INCLEMENT WEATHER, POSTPONMENT and/or EVENT CANCELLATION:

In the event of rain or other conditions, it may be necessary for the Race Director/Promoter or INEX to adjust the order of the Event schedule, length of Race(s), practices, and qualifying sessions, or to stop the program completely. Should this occur, the Race Director/Promoter or INEX shall make every effort to resume the schedule in a timely fashion if conditions improve. It is their sole discretion as to what decision they make, and their decision is final including cancellation of the remaining incomplete portion of an Event.

INEX reserves the right to impound any Legend/Bandolero or any component on a Legend/Bandolero (including the engine) at any time during an Event. The Competitor will surrender the car and/or assist INEX in removing any component(s) requested by INEX. Illegal components, components not permitted for use or in violation of these rules will be confiscated and become the property of INEX. INEX has no responsibility to financially compensate the competitor for the confiscated car or component, whether returned or not.

MEMBERSHIP REQUIREMENTS:

INEX MEMBERSHIPS (Member and Associate):

All Competitors must have submitted an INEX membership application to be permitted to compete in any INEX Sanctioned Event. To receive points for competing, each Driver must have been issued and maintain a valid INEX membership and INEX member number. Without a membership a competitor may be denied participation in an INEX Sanctioned Event, unless they receive prior approval from INEX Headquarters when registering for the Event.

Application forms for an INEX membership can be found on the Pit Pay App. INEX Headquarters is solely responsible for approving and processing such memberships. Membership application and release forms must be fully executed on the Pit Pay App., signed by the applicant, and/or parent, or legal guardian (if applicable) and accompanied by the appropriate funds. The applicant will be considered a member of INEX upon the issuance of the INEX Membership number. **INEX reserves the right to deny membership to any applicant for any reason in INEX's sole and absolute discretion. Applicants will be advised in writing by the INEX**

Membership Department if their application for INEX membership has been denied. All memberships are provisionally in effect once the application is submitted to an INEX representative (through the Pit Pay App.).

Memberships are issued on an annual basis beginning January 1 and expiring December 31 of that calendar year unless otherwise noted.

All applicants applying to INEX as a Driver that submit an INEX membership application through the Pit Pay App. at the track will be awarded points earned that day/date and forward (if the application is filled out properly and an INEX membership number is issued).

ALL INEX members and Associate Members are independent contractors and are neither agents, servants, nor employees of INEX. INEX members assume and take full responsibility for reporting and paying to the appropriate authorities all charges, premiums, and taxes, if any, due or payable on funds or benefits INEX members may receive because of their participation in INEX Sanctioned Event(s).

Membership requirements for individuals under 18 years of age:

If the applicant is under 18 years of age, a minor/parent and/or guardian releases signed (one by the mother and one by the father or legal guardian {with supporting legal paperwork}) must be executed. A government issued birth certificate must also be submitted with the INEX membership application and all release forms.

A MINOR applicant (age 17 and under) must also have a parent(s) or guardian(s) as an INEX Associate Member. Any documentation provided that falsely represents name, age, date of birth, or birthplace, could result in immediate and indefinite suspension.

Any Driver under 18 years of age must receive approval to compete from the Track Promoter prior to the Event, to be eligible to compete at that Track. The Track Promoter's decision is FINAL. INEX has no authority in this matter, or any Track matters, regarding Driver's age.

Event Release and Indemnity Agreements:

Every Competitor, Official, worker and participant who is issued a pit pass or other such credentials permitting access to the pits and track, Competition areas and restricted areas must first sign a Release and Indemnity Agreement as provided by the Track.

It will be considered a serious breach of these rules to enter such controlled restricted areas of the Track without first signing such Release and Indemnity Agreement, to secure a pit pass or other credential under false pretenses or to transfer such a credential to any other person. Each participant in Competition has the responsibility to assess the safety aspects of facilities, including the racing surface, and assume the risk of Competition. Any participant's concerns should be brought to the attention of the Promoter or Race Director of that Event before the participant competes in any on-track activity.

The Promoter can prohibit participation by any Competitor at their discretion.

Membership Violations:

Any INEX member(s) that loans or allows another individual(s) to attempt to obtain pit passes or other credentials for an Event(s) or other membership benefits by the use of membership number is subject to Penalty that may result in suspension of their membership. Any documentation provided that falsely represents name, age, date of birth, or birthplace, could result in immediate and indefinite suspension.

MEDICAL ATTENTION/INJURIES:

INEX may deny membership of a person based on past medical conditions that may affect the safety of that person or other participants at an INEX Sanctioned Competition.

It shall be the personal responsibility of all members to refrain from taking part in any INEX Sanctioned Event if they have been injured, are under the influence of alcohol or any controlled substance or are medically unfit in any way.

Medical Injuries Reporting: It is the responsibility of all members to report any injuries suffered at an INEX Sanctioned Event BEFORE leaving the property of the Track where the injury occurred. **THE MEMBER MUST SUBMIT THE ACCIDENT REPORT TO THE PROMOTER AND/OR RACE DIRECTOR BEFORE LEAVING THE PREMISES.** Failure to submit the accident report may nullify all injury claims to the Track's and INEX's insurance companies. An injured member(s) must follow-up on their accident claims by contacting INEX Headquarters the next business day.

NOTE: Participants may obtain accident report forms by request from the Track or INEX Headquarters.

EVENT INSURANCE COVERAGE:

INEX Minimum Event Limits:

INEX requires that each Track / Promoter of an INEX Sanctioned Event obtain proper liability and participant accident insurance in the following minimums:

1) Medical Coverage—minimum \$5,000.00 primary or secondary participant accident (PA) medical coverage.

2) Accidental Death & Dismemberment Benefits -minimum \$5,000.00.

3) Participant Legal Liability Coverage -minimum \$1,000,000.00.

4) Spectator Legal Liability Coverage -minimum \$1,000,000.00.

5) Name as an additional insured on the policy -INEX, USLCI; Speedway Motorsports, LLC; Sonic Financial Corporation, Speedway Holdings I, LLC, Speedway Holdings II, LLC, and all affiliates and Officials. Event liability insurance for INEX Sanctioned Events automatically must cover all participating INEX members, Drivers, crew members, car owners, Authorized USLCI dealers and sponsors as well as INEX or USLCI. The Promoter must submit the Track insurance policies to INEX Headquarters for approval two weeks prior to the opening date of the Sanctioned Event.

Insurance Provided for Members/Associates:

INEX has an excess medical insurance policy covering licensed INEX members and Associate Members. The insurance is enforced only while they are competing in an INEX Sanctioned Event(s).

1) Excess Medical Coverage-provides up to \$100,000.00 excess individual medical coverage over a participant's personal policy and/or the mandatory minimum Track insurance of \$5,000.00.

2) Accidental Death & Dismemberment Coverage for Up to 365 Days -provides \$25,000.00 accidental death & dismemberment due to a competition related accident occurring during an INEX Sanctioned Event only.

3) Temporary Total Disability Policy Coverage-starting on 8th Day of Disability \$100.00 per week for a maximum of 26 weeks (Contact INEX Headquarters for details).

As an INEX member or Associate Member, you agree that your beneficiaries, executors, and assigns will be entitled to the benefits of the Member Accident Insurance Policy procured by INEX for accidental injuries or death which occur as the result of external, violent, and visible means, sustained in INEX Sanctioned Events. The coverage of the said

policy shall constitute the limit of liability of INEX and USLCI and affiliates for such injuries occurring to the undersigned in any INEX Sanctioned Event, provided proper notification of such Occurrence is filed with INEX Headquarters.

INSURANCE CLAIM SUBMISSION PROCESS:

When submitting an insurance claim, the INEX member and/or Associate Member will apply for coverage through their personal insurance provider first, then to the Track's insurance company and then through the INEX Headquarters. INEX will forward to their insurance provider, (in that order) providing the accident forms are completed.

CONTROLLED SUBSTANCE ABUSE POLICY:

INEX is concerned about the effects of drug and alcohol abuse upon the health and safety of our members. INEX recognizes that the abuse of drugs and alcohol results in increased accidents and the need for medical treatment as well as adversely affecting family life. People who abuse drugs and alcohol at a track are not only a danger to themselves, but to their fellow competitors. Considering these concerns, INEX intends to maintain a Series free of the problems associated with the abuse of drugs and alcohol and will work towards providing the safest possible environment for all participants and spectators.

In the interest of maintaining the integrity of Legend Cars and Bandolero Cars racing, INEX has established a Substance Abuse Policy and may from time to time conduct tests for drugs and alcohol use that may adversely affect a person during any INEX Sanctioned Event. In association with any INEX Sanctioned Event, it is INEX's policy that it is strictly forbidden for any participant or member to be involved with the unlawful use, possession, sale or transfer of drugs or narcotics, and further, that participants or member shall not possess, consume or be under the influence of alcoholic beverages for an INEX Event.

In order to protect the interest of INEX, its membership and the general public, INEX may take reasonable measures to determine if illegal drugs or alcohol are located on or being used or consumed upon Track property or before arriving on the Track property if reasonable suspicion is present. Factors which may establish suspicion include, but are not limited to, significant changes in personality; dramatic mood swings; abusive behavior; reliable reports from other participants, members or credible sources; unusual, irrational or erratic behavior;

difficulty in motor skills coordination, poor muscle control, unsteady walking, nervousness or slurred speech; impaired short term memory or illogical thinking; or the direct observation of drug or alcohol use or discovery of evidence of drug or alcohol use in the participant's vicinity.

The reasonable measures taken to detect drugs or alcohol may include at the discretion of INEX or the Promoter, but shall not be limited to, the testing for such substances done at the expense of INEX or in certain cases at participant's own expense.

Reasonable searches and inspection of a participant's property may be conducted by authorized personnel at the request of INEX or the Promoter while on the Track property.

Compliance with the INEX Substance Abuse Policy is an essential precondition to the issuance of a membership. Any violation of the policy or refusal to submit to the testing, searches, or inspections as requested by INEX or the Promoter will result in the immediate cancellation of membership and loss of the right to compete in any INEX Sanctioned Event for an indefinite period. Local, state, or federal authorities may also be notified in the event unlawful drug possession or use is suspected.

All participants (members) are strongly encouraged to seek professional help before abuse of drugs and alcohol at a track is detected and thus before any disciplinary actions are implemented.

DRIVER ABILITY RESPONSIBILITIES:

If proof of driving ability is deemed necessary, driving tests may be conducted at the discretion of INEX Competition Director or Track Race Director. It is the Track Race Directors option to approve or deny the applying member to compete in the Event. When deemed necessary, INEX Competition Director may require a physical examination of the applicant or member. It is the responsibility of every Associate Member or Competitor to notify the Race Director of any medical condition that may be worsened by participation at that Event. Permission to compete following such notification does not create an assumption of liability on the part of the Track's Officials or INEX.

ADVERTISING AND PROMOTION RELEASE:

In consideration of entering into any INEX Event, members, Driver and/or Associate Members and participants agree to permit INEX and USLCl and its assigned, the use of names, images, likenesses,

voice, and pictures of himself/herself (the “NIL”) and pictures of their car for INEX’s and USLCI’s own publicity, advertising, endorsements, both before, during and any time period after any INEX Sanctioned Event, and relinquishes and assigns to INEX any rights to photos and video taken in connection with INEX Sanctioned Events, and consents to the publication or sale of such, NIL, photos and video by INEX.

TECHNICAL INSPECTION PROCESS:

Upon entering an Event, any car, or component(s), may be inspected to confirm legality at any time by an INEX Official or representative. Upon entering a car for an INEX Event, the Driver is responsible for the legality of the car and component(s) and will incur all penalties resulting with rule(s) violation(s). Refusal to submit a car or component(s) for inspection upon the request of an INEX Technical Inspector during an INEX Event will result in an immediate Disqualification and additional penalties, including suspension at the INEX Competition Director’s discretion.

No car or component(s) will be considered as having been approved or legal by having passed through an inspection unobserved. Regardless of a Car passing prior inspections, compliance with all rules in the rulebook or amendments issued by Bulletin must be made at each inspection. No expressed or implied warranty of safety shall result from the technical inspection or approval.

INEX OFFICIALS:

Every INEX employee and Official is expected to conduct themselves in a positive professional manner, which will reflect credit on the sport of Legend Cars / Bandolero Cars Racing and INEX. INEX may remove an Official’s appointment or may penalize that Official if they fail to conduct themselves properly. All INEX members and /or Associate Members agree to abide by the Official’s decisions until the decisions are appropriately appealed to INEX Headquarters.

INEX TECHNICAL INSPECTOR:

The INEX Technical Inspector is an independent contractor who is not directly employed by INEX.

The INEX Technical Inspector(s) will also assist in verifying that all Drivers are members of INEX.

INEX Technical Inspector(s) are responsible for checking cars for eligibility and legality. It is the Technical Inspector's responsibility to interpret and administer the rules as contained in this rulebook consistently, impartially, and fairly with all participants. Once a car is registered to Race, the Technical Inspector may require inspection of any car at any time to verify its eligibility and legality. The Technical Inspector will conduct inspections and will report to the Race Director and INEX Technical Director about car(s) that they determine to be ineligible or illegal during an INEX Event. INEX Technical Inspector's decision is final at the Event. Their decisions may only be overruled by the INEX Technical Director, if appropriate. A Competitor and/or Associate Member that does not accept this decision has an opportunity to appeal that decision. If an appeal is filed, all conditions listed under Appeals Process elsewhere in this rulebook, must be adhered to.

INTERPRETATION / APPLICATION OF RULEBOOK:

The INEX rules are designed to ensure that all INEX Sanctioned Events are conducted in a manner that is fair and consistent for all competitors. On occasion, circumstances will arise that are unforeseen and/or extraordinary. At these times, strict application of the INEX rulebook may not achieve this goal. In this circumstance, INEX Officials may decide, regarding the conduct of an Event, the eligibility of a Competitor, or car (or component(s) of a car) and whether they are consistent with the INEX rules. To achieve this goal, rules, entry forms, Bulletins, etc. may contain the term "E.I.R.I." to indicate the likelihood that such a determination may be made by the INEX Officials. However, INEX Officials may make such determination even if E.I.R.I. is not listed in a rule, Bulletin, etc. Such determinations made by INEX Officials are reviewable by INEX Headquarters through the listed process outlined in the "appeals" section of this rulebook.

CAR ENTRY FOR COMPETITION:

Upon entering for Competition any car may be checked for engine, chassis, oil, fuel, tires, wheels, rear ends, or sound (Db levels) legality at any time by an INEX Official or representative. Upon entering a car for INEX Competition the Driver and/or Associate Member is responsible for the legality of their car and will suffer all penalties resulting with the Car violating these rules. **Refusal to submit a car,**

engine or parts for inspection or measurement upon the request of an INEX Technical Inspector will result in an immediate Disqualification and may lead to a suspension or other Penalties issued by INEX for car, Driver, and/or Associate Member.

No equipment or Racecar will be considered as having been approved by reason of having passed through inspection unobserved. Regardless of the car passing prior inspections, compliance with all rules must be made at each post-Race inspection. No expressed or implied warranty of safety shall result from the technical inspection or approval.

ENFORCEMENT OF SPECIFICATION RULES / MEASURING EQUIPMENT:

All INEX approved weighing, measuring, and testing devices used by the INEX Technical Officials are the standards, which will determine compliance with the rules and regulations.

A competitor's equipment, gauge, or instrument will have no influence on the enforcement of these rules, unless approved to be the standard and used by the INEX Technical Inspector. The Car's engine must start in inspection area, to perform inspections that require the engine to start.

Ineligible Component(s) discovered after Competition:

If an INEX Official determines, after a Competition, that a car or component(s) does not meet the specifications as listed in the INEX rules but the deficiency is so insubstantial as to not have affected the outcome of the Event, the INEX Official, in his/her discretion, may determine that the car (or parts) were eligible for that Event but will notify the Competitor and/or Associate Member in writing (through the INEX Technical Director) to correct the deficiency for future Events. That car or component(s) will be prohibited from future Events if the deficiency is not corrected by the date set by the INEX Technical Director.

New Enforcement Procedures and Equipment:

Due to the rapidly changing technology of Motorsports, INEX will continue to develop new procedures and equipment to enforce the INEX rules. These procedures and equipment will be based on common sense, consistency, and impartiality. These procedures and equipment may be implemented at any time without prior notice to the participants.

Race Director (employee of the Promoter, not INEX): The Race Director is the person at an INEX Event who is responsible for the conduct of the Event. The Race Director is responsible for executing the program of Competition and other activities by directing the Drivers and their cars, Officials and their assistants, and other participants. The Race Director is also responsible for settling questions and disputes related to on-track activity and procedures, supervising the Event and determining whether conditions are safe to continue the Event (altering the schedule for reasons of safety or forces beyond their control) or postponing the Competition. The Race Director will settle all disputes relating to local Track Race procedures.

RACE PROCEDURES AND LINEUP RULES:

Across the United States, Canada, Mexico and Europe, the Race procedures, lineup procedures and flags vary from Track to Track. It is impossible for INEX to make any decisions concerning on-track incidents except for incidents involving unsportsmanlike conduct. All INEX Events have been and shall remain to be governed by the on-track Race procedural rules of the individual Tracks where the Legend Cars and/or Bandolero Cars are competing.

The Promoter shall appoint a Race Director at their sole discretion. The Race Director will determine, administer and perform all racing, flagging and lineup procedures except for the bumper rule: A car must compete with both bumpers that are not in contact with the track or considered in a dangerous position or condition by Track Officials at any time. If any of these conditions are not met, Track Officials may black flag the car.

If a Driver and/or Associate Member should have any questions about these procedures at an Event (such as starts, restarts, flags, line-ups, rough driving, etc.), they should inquire at the Driver's meeting or direct their questions to the Race Director. All "on-track" or Race procedural disputes, protests or concerns should also be directed to the Race Director for the final decision to be settled at the Track.

Suggested Flag Usage

Provided as a suggested manner of flag usage (Template) for a Track Event, as noted above, each Track is responsible for their adaption of flag usage and will be explained in the Drivers Meeting.

Yellow Flag-Please pay close attention to the starter and caution lights around the track. Once the caution lights are illuminated and the Yellow flag is displayed, the track is under caution, slow down and get single file. **Do not race back to the start/finish line.**

Car(s) that spin are expected to either rejoin the race as quickly and safely as possible or clear the racing surface quickly and safely. If the Race Director deems that you intentionally brought out the caution you may be Black-flagged. If you are deemed to be stopped in a safe location the track will remain under green. Please do not disconnect any safety equipment and remain in your race car.

Work is permitted on your car during a Yellow flag in the designated work area only and restart at the tail end of the longest line (no lane selection option).

Blue Flag with Yellow Diagonal Stripe-If the Blue flag with the Yellow diagonal stripe is displayed to you, please be courteous and yield to the overtaking cars.

Red Flag-The Red flag means **STOP** as quickly and safely as possible. Safety workers and equipment will be on the track and the Red flag is for everyone's safety. You will only move if instructed to by safety personnel and/or the Race Director.

Work is permitted on your car during a Red flag in the designated pit area only and restart at the tail end of the longest line (no lane selection option).

Black Flag-The black flag will be displayed at the start/finish line and the car being penalized will be announced over the One-Way Radio, by the Race Director. If you receive the black flag you must exit the track.

Any display of rough driving in any race will result in the offending Driver being black flagged and parked for the remainder of that race.

If you have two unassisted spins in any race or are unable to maintain a safe speed you may be Black flagged at the discretion of the Race Director.

White Flag-The White flag will be displayed at the start/finish line as the leader starts the last lap of the Race.

Checkered Flag-The Checkered flag will be displayed at the start/finish line to indicate the Race is finished.

Miscellaneous Flag usage (may vary from Track to Track)

Failure to heed **ANY** flag may result in penalties. Penalties may include loss of laps, points, monetary fines, suspensions, etc., at the discretion of the Race Director.

Race Procedure / Bumpers are Mandatory

A car must compete with both bumpers that are not in contact with the track or considered in a dangerous position or condition by Track Officials at any time. If any of these conditions are not met, Track Officials may black flag the car.

NOTE: The INEX Technical Inspector does not have the authority to disqualify a Driver after the Race for a violation of this Race procedure.

Time Limit of Race

Tracks may establish time limits for races and will be explained at the Drivers Meeting.

Scoring

Drivers, please make sure you have charged your transponder and mounted it properly on your car prior to any on-track activity. It is your responsibility to make sure that your transponder is always properly mounted and in working condition when the car is on the track.

All Competition results (qualifying, heats and feature races) will be sent to the designated location in a timely manner after they have been verified by scoring.

Original Starts and Restarts

Once the pace car has exited the track, the front row cars must maintain Pace Vehicle speed and may not

start racing until the restart zone / line (reviewed and defined in the Drivers Meeting).

All cars are to stay double-file, side by side in nose-to-tail formation without bumping or pushing. Once the Green flag has been displayed, you may pass (how and where, to be reviewed in the Drivers Meeting), penalties are at the judgement of the Race Director.

If a lap is not completed all cars will get their original starting spot, minus the cars involved in the caution.

Suggested Race Procedure (Template) Tracks may use variations

Start & Restarts – Defined

- When the Green flag waves, you may pass to the right and ONLY to the right until you cross the start/finish line (circle track). You may not pull out of line to the left before you cross the start/finish line

CAUTION Periods

- Cars that are involved in an incident (a spin, wreck, etc.) are expected to clear the racing groove quickly and safely. Make sure you turn away from traffic e.g. turn through grass away from the track.
- If you lose power or toss a chain, please get off the track to a safe area as soon as possible.
- Any car involved in an avoidable caution meaning they could have cleared the incident instead of causing a yellow flag to be displayed will be penalized at the discretion of the officials.
- Any car causing an intentional yellow flag may be black flagged for that race.
- Driver should stay with car if wrecked

A race ending under review means that Officials are reviewing the race for violations and may assess penalties on car(s) involved in an altercation during the race. Finishes are Official 30 minutes after posting the results.

NOTE: Both the Flag Rules and Race Procedures listed in the previous section are provided to the Tracks as a template for competition and are NOT INEX Flag or Race Procedures rules. Please

request copies of both from the Local Track Rules, review with the Race Director and ask questions in the Drivers Meetings until you understand the flags and rules enforced at each racetrack.

Conduct & Pit Area Rules

- NO Aggressive Driving
Respect Competitors and obey Officials and Safety Workers
- Please use the Safety-Kleen or recycling location for all oil dump and cleaning of parts-The Race Team is responsible for following all Local, State and Federal regulations

PARTICIPANT CODE OF CONDUCT:

INEX members, Associate Members, and participants at INEX Events are always expected to conduct themselves in a professional and non-disruptive manner.

Any member, Associate Member, or participant(s), who within the boundaries of the Track facility or otherwise, in the sole judgment of the INEX Competition Director:

- Physically assaults another participant, Official or other person
- engages in any conduct deemed by INEX in its sole and absolute discretion to be detrimental to the sport of, Legend Cars, or Bandolero Cars racing
- Otherwise creates a condition or circumstance which is unsafe, unfair, or out of order, shall have violated the rules and regulations of INEX and may be penalized.

The Driver and/or Associate Member is responsible for the conduct of their crewmember(s) or anyone else associated with their team. A Driver may suffer the penalties for the conduct of their crewmember(s), Associate Member(s), or guest. When the Driver(s) are under 18 years of age the designated Associate Member (parent or guardian) is responsible for Driver, crewmember(s) and/or anyone associated with their Team. In this circumstance the penalties may still be imposed upon the Driver as well as the Associate Member.

Physical violence violations may also be prosecuted through Local, State or Federal enforcement authorities.

“2-2-2” Policy -Should a Driver and/or Associate Member or crew member be deemed by INEX Competition Director to have committed an unsportsmanlike act (either on or off the track) that is detrimental to the sport of Legend Cars and Bandolero Cars racing, the minimum Penalty in which they will receive is a two (2) week suspension, two (2) month probation and a \$200.00 fine. Conduct penalties will be issued by the INEX Competition Director or by the Promoter after consultation with the INEX Competition Director.

PENALTIES FOR RULE INFRACTIONS:

Any Driver, member, participant or Official who violates the rules found within this rulebook or succeeding amendments, attempts to bribe anyone connected with an INEX Event, or is party to a fraud or other act prejudicial to INEX and the good reputation of the Legend Cars or Bandolero Cars racing may be penalized accordingly to the nature of the offense by the Race Director (employee of the speedway) or the INEX Competition Director.

All penalties and Disqualifications for technical rule(s) infractions will be issued by the INEX Tech Inspector per the direction of INEX Technical Director.

INEX Headquarters shall have the right to publish notice that it has imposed a Penalty and the reasons therefore, and the person or body referred to in such notice shall have no right to act against INEX or the person publishing the notice. The determination of penalties(s) will be the decision of INEX Competition Director.

Types of penalties that may be imposed for infractions:

1)* Probation -After a participant is warned and if another similar infraction occurs during the time of probation, the Promoter or INEX Competition Director may impose a harsher Penalty onto that member.

2)* Race Procedure Penalty -A Penalty such as loss of position (i.e. placed at the rear of the field) during or after a Race depending on the infraction, issued solely by the Race Director.

3)* Total or Partial Loss of Race Points -Total or partial loss of track, state and/or national points earned during an INEX Sanctioned Event may be imposed by INEX Headquarters.

4)* Disqualification -The Race Director or INEX Technical Inspector may disqualify a Competitor from a Race, in which any awards earned in the Competition (such as points, money, positions, contingency awards, etc.) are forfeited, and the Officials will advance the competitors in that Race accordingly.

5)* Confiscation of Illegal or Unauthorized Components (to include but not be limited to, car, chassis, engine, equipment, etc.) – INEX has the right to confiscate any illegal, unauthorized, altered, or non-conforming component(s) and/or Race equipment without obligation for payment or reimbursement. The use of illegal or unauthorized components will result in the confiscation, by an INEX Technical Inspector, of said components. These components will then become the property of INEX and will not be returned. Failure to surrender the illegal parts to the INEX inspector may lead to additional Penalties ranging from probation to expulsion for the car owner, car, and Driver (and Associate Member when applicable). This/these Penalties may remain or increase depending on the circumstances until the said illegal component is turned into INEX Technical Director. Additional penalties may be administered at that time.

6) Fine** -A fine may be imposed by INEX Competition Director and a written notice sent to the member. The fine must be paid within the period specified on the notice or the participant's privileges are automatically suspended until the fine is paid. All fine payments must be remitted to INEX Headquarters unless a separate fine is issued directly by the Promoter, which is then to be paid to the Promoter according to their guidelines

7) Suspension** -Only INEX Competition Director or Promoter (at their Track) may suspend a Competitors privileges to take part in Competition for a definite or indefinite period. Any member under INEX local, state, or international suspension, or otherwise disciplined under these rules of Competition, may be reinstated by action of, and in the sole discretion of INEX Competition Director. Promoter suspensions will not be reinstated by INEX.

8) Total or Partial Loss of Accrued Points** -Total or partial loss of accrued Track, state and/or international points earned by a competitor during the season may be imposed by the INEX Competition Director.

9) Expulsion** Only the Promoter (at their Track) or INEX Competition Director may expel a member for serious or repeated offenses.

*INEX, the Race Director, Promoter or the INEX Technical Inspector shall impose penalties #1 through #5 listed above.

**Only INEX Headquarters shall impose penalties #6 through #9 at its own discretion or at the request of the Race Director, Promoter or INEX Technical Inspector. All parties concerned shall be bound by the decision given, subject only to appeal as hereafter provided.

DISPUTE OF A DECISION:

Any dispute, controversy or claim involving members, Associate Members and participants, whether or not relating to this rulebook or alleged breach of the same, shall be settled in accordance with the existing and/or amended rules and regulations of INEX, and they agree to accept the decisions rendered by such process. The Promoter or Race Director is solely responsible for settling all disputes developing because of local Track Race procedure rules.

All INEX members, Associate Members and participants expressly agree that determinations by INEX or track Officials as to the applicability and interpretation of these rules are non-litigable, and they agree that they will not initiate or maintain litigation of any kind against INEX or anyone acting on behalf of INEX, to reverse, modify or obtain relief from such determination. If a member or participant initiates or maintains litigation in violation of this covenant, that person agrees to reimburse INEX for the costs of such litigation, including all reasonable attorneys' fees. That member, associate member or participant will also be suspended from any INEX sanctioned event or Competition during the entire time of such litigation.

APPEALS PROCESS (FOR PENALTIES):

The Driver or Associate Member, directly affected by the at-track Penalty, must give notice of their intention to appeal to the Race Director or Promoter as well as the INEX Technical Inspector within fifteen (15) minutes of the issuance of the Penalty in order to withhold the payment of any purse or issuance of points for that Event. The formal appeal must be submitted to INEX Headquarters within four (4) business days after a Penalty has been issued. If no appeal has been received at INEX Headquarters within four

(4) business days, the purse and points will be issued. The Driver may or may not be allowed to compete until the appeal is heard, but the purse and all points will be held pending the outcome of the appeal.

Only a Driver or Associate Member may file an appeal against a technical (specification) Penalty or a conduct Penalty (when issued by INEX) issued against them. **Penalties involving on-track Race procedures or judgment calls will not be considered for appeal by INEX.** Penalties can be appealed by posting \$250 with INEX. And additional \$1,000 will need to be posted with INEX to appeal shock, engine seal, tire soaking, 1200 engine specifications, and traction control penalties. **Appeals must be written clearly stating the specific basis of the appeal, signed by the appellant, accompanied by the appeal fee(s), and received by INEX Headquarters within four (4) business days of the notification of the Penalty to the Competitor. Appeal(s) may be hand delivered to INEX Headquarters or via express /registered mail to evidence the delivery to:**

INEX - ATTN:
Appeal Notification
C/O Competition Director
5245 HWY NC 49 South
Harrisburg, NC 28075

If the above provisions are not followed, the appeal may be disallowed.

THE FIRST REVIEW OF AN APPEAL WILL BE DONE BY THE INEX COMPETITION DIRECTOR. THE INEX COMPETITION DIRECTOR SHALL DECIDE WHETHER AN APPEAL SHOULD BE HEARD BASED ON THE FACTS OF THE APPEAL, AND THAT DECISION WILL BE FINAL. The INEX Competition Director will then notify the appealing Driver or Associate Member within 14 days of the decision to proceed or not with the appeal.

If an Appeals Committee is chosen- The Appeals Committee will consist of representatives appointed by INEX. The Appeals Committee shall meet and render a decision on the appeal as promptly as possible. At the time of the appeal hearing, all relevant facts will be heard, persons involved will receive a reasonable opportunity to be heard, and other relevant information will be presented.

The appeal hearing shall be limited solely to the specific reason(s) stated in the appeal. The Appeals Committee shall not be required to employ technical or formal rules of evidence or procedure. They shall determine the most effective procedures for developing the relevant facts and arriving at a conclusion. **The INEX Driver or Associate Member may appear in person, by telephone, or by videoconference in hearings before the Appeals Committee. INEX Members and/or Associate Members may not appear through a representative or legal counsel or have a representative or legal counsel present during the appeal process.** The Appeals Committee may summon any INEX Member or Associate Member to testify during the appeals process. Any person failing to comply with requests by the Appeals Committee will be subject to disciplinary action as determined by INEX Competition Director. The Appeals Committee will render a decision based on a majority of the committee members concurring to modify the Penalty or not modify the Penalty. A previously imposed Penalty may be waived, decreased, remain the same or increased. If the Appeals Committee fails to agree on an action to be taken on the appeal, the appeal shall be referred to The INEX General Manager for a final decision. Written documentation of the decision will be distributed to the appellant and all parties involved in the appeal. The \$250 or \$1,000 (for shock, engine seal, tire soaking, 1200 engine and traction control) appeal fee will be used for the costs specific to the appeal & any fines issued by the Appeals Committee or INEX. Any unused portion of the fee(s) will be returned to the appellant. INEX shall have the right to publish notice of the decision and to use the names of the parties involved. The person or body referred to in such notice shall have no right to act against INEX or the person publishing the notice. Once a decision has been determined by the Appeals Committee or INEX, that decision is then FINAL and not litigable.

The INEX Competition Director may penalize the author of an appeal deemed to be malicious, spiteful, or who otherwise acts in bad faith.

FILING A COMPLAINT:

If an INEX Driver or Associate Member should have any concerns about a Track, a Promoter, certain Race procedures, Technical Inspection, Officials, etc., please contact INEX either by phone or in writing (preferred).

ACCOUNTS RECEIVABLES:

All competitors must remain in good standing with

INEX, USLCI and the authorized USLCI dealer network to remain eligible for Competition. The INEX Competition Director may suspend an INEX member from all INEX events for not paying their bills (to INEX, USLCI or its dealer network) in a timely manner. After payment request from the dealer or USLCI is submitted to INEX, These participants will be notified in writing that they are suspended from all INEX Events. When the bill is paid in full, that suspended participant will be permitted to compete. Personal checks written to INEX, USLCI or the dealer network with non or insufficient funds will result in immediate suspension from all INEX sanctioned events until the debt is cleared. INEX or USLCI will impose an insufficient fund fee of \$ 50.00

DRIVER DIVISIONAL STRUCTURES:

LEGEND CARS:

The minimum age for Legend Cars Competition is 10 years old.

Legend Cars Divisions:

1) PRO (Expert Class): Designed for experienced Drivers. The Driver must have competed in some other form of professional motorsports or have competed in the Semi-Pro, Masters, or Young Lions division in the Legend Cars to be eligible. This is the pinnacle class of Legend Cars racing and will be treated as such. Approval to compete in this class will be the decision of INEX Competition Director.

2) MASTERS: Drivers 40 years old and over as of January 1, 2025.

If a Driver reaches 40 years of age during the 2025 calendar year, that Driver will have the option to advance to Masters on their birthday. This move is not automatic, and a written request is required from the Driver to INEX Competition Director.

3) GOLDEN MASTERS: Drivers over 60 as of January 1, 2025 (and will be included as Masters).

The top Golden Master Driver will receive an additional award at certain Events. Also, INEX will recognize a Golden Master Champion at the end of the season for Asphalt, Road Course, and Dirt Points.

4) SEMI-PRO: Drivers 16 years old and older as of January 1, 2025 (E.I.R.I.):

Designed for Drivers who are starting out in Legend Car racing or moving from (timing out) of the Young Lions class only. No prior experience is necessary, new racers may be

required to compete in consolation, B Mains, and/ or start in the rear of the field. The decision to start a Driver to the rear of the field will be at the discretion of the Race Director.

5) YOUNG LIONS: Drivers 10 - 15 years old as of January 1, 2025. Drivers may stay in this division for a maximum of three years (minimum of 15 races each year) and then advance to Semi-Pro or Pro (with approval from the INEX Competition Director). If a driver is deemed to need more experience by the INEX Competition Director, that driver will be allowed to remain in the Young Lions division longer than the three year maximum. Young Lion Drivers may advance into the Semi-Pro class if they turn 16 during that calendar year. This requires a written request from the Driver to the INEX Competition Director. All Drivers under 16 years of age must receive approval to compete from the Track Promoter prior to the Event to be eligible. The Track Promoters decision is FINAL. INEX has no authority in this matter of eligibility.

10 & 11 year old drivers are required to have competed in two years of documented Bandolero competition (minimum of 15 races per year).

OR

Have two years of documented racing experience in karting, quarter midget or other form of sanctioned racing (approved by INEX) including, but not limited to W.K.A., Q.M.A., USAC .25 / The NASCAR Youth Series, U.S.P.K.S., S.K.U.S.A., ROK Cup U.S.A. Such driver must also provide two non-family references that can verify the drivers racing experience (example = track staff, series officials, race directors, track promoters). INEX will decide in its sole and absolute discretion whether to accept any particular reference.

DIVISIONAL (CLASS) CHANGE / LEGEND CARS

Any Driver desiring to change divisions must first receive approval from the INEX Competition Director in writing. Drivers requesting to move down in status must show proof that they are not properly classified. Points accumulated during the season will not be transferred if a driver changes their division during the season.

INEX reserves the right to place any Driver into a different division (up or down) at its own discretion at any time. Professional drivers entering Legend Car racing will be required to race in the pro division (E.I.R.I.). A Driver cannot change division at the track the same day of a Race and cannot change points and/or classification prior to approval of the

division change by INEX headquarters.

Running separated divisions in separate Races will be at the Promoter's discretion depending on the car count at that Track and the time schedule. A Driver may only compete in one division if the Event offers separate divisions (Pro, Masters, Semi-Pro) or any combination thereof.

BANDOLERO CARS:

The minimum age for Bandolero car competition is 7 years old.

Bandolero Car Divisions:

1) BANDITS: (Drivers between the ages of 7 -11) as of January 1, 2025.

2) OUTLAWS: (Drivers age 12 and older) as of January 1, 2025.

DIVISIONAL (CLASS) CHANGE / BANDOLERO CARS

Once a competitor begins a racing season in one division (age-related division), they can compete in that division for one calendar year (January 1- December 31). Bandit Drivers may opt into the Outlaw class if they reach 12 years of age during that calendar year. Any mid-season changing of division must be approved by INEX Competition Director.

NOTE: Any points accumulated during the season will not be transferred if a Driver changes their division during the season.

POINTS SYSTEM:

The INEX Regular Points season is from February 10th through October 5th of 2025.

To receive points for competing, each Competitor must have been issued and maintain a valid INEX membership and INEX member number.

All Tracks and/or local series will establish their own policies for awarding points for their own seasons. INEX does not control or determine how these local or regional points will be issued.

The following rules will determine INEX points awarded in all INEX State, INEX International, and INEX International Tour classes:

* INEX recognizes Young Lions, Semi-Pro, Master, Pro, Bandit & Outlaws as INEX points classes.

* Beginner Bandolero, Rookie, Charger, Etc. classes are not INEX points classes and will not receive INEX points. These classes (Beginner Bandolero, Rookie, Charger, Etc.) may be eligible for track / local points only.

1. Only Drivers receive points, not the car or team owners. Only licensed INEX Drivers will receive points at INEX Events. It is the Driver responsibility to verify that each Race is an INEX International Points Event and that the Track submits Race results to INEX Headquarters. Drivers submitting an INEX application, properly filled out, submitted to a certified INEX Official and approved by INEX, prior to the Race, will count as a licensed member.

2. All rescheduled races (rainouts) will be on off days when allowable (with INEX approval). Rescheduled Events for the following day will be allowed without prior INEX approval. Track and local series points issued are at the sole discretion of the Promoter and/or the series director.

3. Promoters may schedule double feature Events with prior approval from INEX. Double feature Events will be allowed as posted by INEX on each Tracks original schedule (as listed on the INEX Sanction Agreement). Unless specifically scheduled and approved, all Drivers will receive INEX points for one feature Race per surface type, per day. In the case of an unapproved double feature Event, only the first feature will count towards INEX points. Adding double feature events or Qualifiers will not be permitted within one month of the end of the INEX Regular points season.

4. A Driver must compete in a feature Race or semi-feature Race (B-main) to receive points. There will be no points awarded if a Driver does not advance past the initial qualifying Events. (E.I.R.I.)

5. Semi-Pros, Young Lions, Master & Pro drivers when racing in the same race will be awarded separate INEX points by class.

6. Events (including B mains) with less than five (5) competitors, for each division, (Young Lions, Semi-Pro, Master, Pro, Bandits & Outlaws) in the feature Race will receive points according to the place finished with "ghost racers" filling the field necessary to five.

- Example-a feature that contains 8 Masters and 3 Pros will award full points to all Masters Drivers, the top Pro Driver will receive points equivalent to 3rd place or 94.

In World Road Racing, the ghost Racers will only fill the field necessary to three.

- Example-a road Race feature that contains 8 Masters and 3 Pros will award full points to Drivers in both divisions.

Non-INEX members/Drivers, Beginner Bandoleros, Rookie, Charger, Etc. competing will not count towards the minimum five competitor requirement (ghost racers rule).

INEX members/drivers (Young Lion, Semi-Pro, Master, Pro, Bandit & Outlaws) competing in a B-main will count towards the minimum five competitor requirement (ghost racers rule).

7. Any feature Race with 15 or more INEX Members competing: the winner will be awarded 100-points regardless of its division's car count competing in said race.

Depending on track availability, time constraints, Promoter's discretion, the divisions may be combined as one feature Race. Drivers will receive INEX points within their respective division.

- Example, if a Masters Driver finishes 5th overall, in a combined Race and he/she is the 1st Masters finisher, and there are five or more Masters then he/she will receive 100 points for 1st place in the Masters division.

8. All results are made Official when received at INEX Headquarters. To be declared Official, results must be on Track letterhead or on the Official Race results sheet issued by INEX or approved by the INEX Sanctioning & Membership Coordinator. Results must be submitted in a timely manner and will not be counted towards Driver yearly standings if received after Friday, October 17, 2025. If you have missing results call your local Track or INEX to arrange to have those finishes submitted. Once posted on the official INEX website, any disputed finishes must be submitted to INEX within a two-week period. A final review of the submitted INEX points will conclude on November 14, 2025 and the INEX points standings will be final.

9. Points are non-transferable between divisions. The Division you declare at the beginning of the season on your INEX membership application and approved by INEX Competition Director is where you will accumulate points. If a Driver changes divisions mid-season with the approval of the INEX Competition Director, the Driver will begin a new

point accumulation for that division and not be eligible for awards/honors earned in the former division.

10. POINTS SCHEDULE

Points are awarded as follows:

Finish	Points	Finish	Points
1 st	100	15 th	68
2 nd	97	16 th	67
3 rd	94	17 th	66
4 th	91	18 th	65
5 th	88	19 th	64
6 th	86	20 th	63
7 th	84	21 st	62
8 th	82	22 nd	61
9 th	80	23 rd	60
10 th	78	24 th	59
11 th	76	25 th	58
12 th	74	26 th	57
13 th	72	27 th	56
14 th	70	28 th	55

11. Interpretation of the rules as they apply to issuing points shall be at the discretion of INEX.

NOTE: Additional dates and schedule changes for Sanctioned tracks, submitted after March 1st 2025, must be approved by INEX to be considered for INEX points. Please check our master schedule at www.INEXseries.com to confirm that each Event is an INEX Sanctioned Event.

12. SPECIAL EVENTS

INEX may award points at Events not included in the regular calendar racing season. These Events will be open to all INEX licensed competitors.

13. B-Feature Race:

- 1) Transfer spots to A-Feature receive zero (0) points until finish in A-Feature.
- 2) Non-transfer spots from the B-main begin at fifty (50) points and reduce by one (1) point per position.
- 3.) B-main (Young Lion, Semi-Pro, Master, Pro, Bandit & Outlaw) Drivers will count toward the total number of drivers in each class for that Event. Technical Disqualifications in a feature Event will receive zero (0) points.

14. TIE-BREAKERS IN POINT POSITIONS

In case of ANY tie(s) in International or State Championship points, the following will determine a champion:

- 1.) The Driver's finishing position at the World Championship Event in that Driver's class.
- 2.) Most 100 Point wins (all Events on specific track surface)

- 3.) Most 97 Points finishes (all Events on specific track surface)
- 4.) Highest point percentage (all Events on specific track surface)
- 5.) Highest top 5 percentage (all Events on specific track surface)
- 6.) Co-Champions (if still tied after all the above)

15. State Championships:

A member will only be eligible to win a state Championship based on the home state as submitted on their INEX application. Drivers must provide a verifiable hard street address. All INEX Races (from any state) will count towards a Driver's state Championship points standing in their home state as listed on their INEX membership.

16. Canadian (East, Central & West)

Championships:

International Points for Canadian Drivers: Drivers using a PO Box for their address must provide a verifiable hard street address. All INEX Races (from any province) will count towards a Driver's province (East, Center & West) Championship points standing.

"Nationals" races

There will be Championship Races (Nationals) held for each racing series (Legend Cars Asphalt, Legend Cars Dirt, Legend Cars Road Course & Bandolero Cars)

Any INEX Driver with a current INEX membership is eligible to compete and encouraged to attend any of these Events.

Local track points will not be counted towards INEX points on the weekends of the "Nationals" races.

PROHIBITED PRIVATE USE FOR PRACTICE OR TESTING AT FACILITIES OF CHAMPIONSHIP RACES (NATIONALS) FOR LEGEND CARS AND BANDOLERO CARS:

It is prohibited that any INEX Member reserve a facility for private practice or testing on the site of any Championship race (Nationals) one week prior to the event. Practice open to all INEX Members is acceptable. Any INEX Member that violates this policy will not be permitted to participate in the Championship race (Nationals) at that facility.

Asphalt, Dirt & Road Course National Qualifier Races/Legend Cars

“National Qualifier” races will be held at various tracks worldwide in which the first Pro, Master, Semi-Pro & Young Lion Drivers will become eligible for a provisional starting spot in their “Nationals” Race. These Drivers will still go through the normal qualifying procedures at the “Nationals” Race. If the eligible starters fail to qualify for the A-Main on their own merits, then the top six eligible provisional starters will be placed to the rear of the A-Main based on their finish in preliminary (B, C, D) Events.

Legend Cars International Asphalt Points Series:

Drivers will accumulate points at INEX Sanctioned feature Events competed on asphalt. A Driver’s best eighteen (18) finishes plus their best “Nationals Qualifier” Race and their finish at the Asphalt “Nationals” Race will count towards their International Points standing. This makes a total of Twenty (20) Races (18 Local Races, 1 “Nationals Qualifier” Race and 1 Asphalt “Nationals” Race). There shall be a point champion in each of the following divisions: Pro, Master, Semi-Pro, Young Lion, and Golden Master. To receive asphalt international Championship awards, prizes, and honors, that Driver must receive points in a minimum of ten (10) INEX Events.

Legend Cars State Asphalt Points Series:

The top Driver in International Asphalt Points from each state will receive the individual state Championship award. There shall be a State Point Champion in each of the following divisions: Pro, Masters, Semi-Pro and Young Lions. To receive an asphalt state Championship awards, prizes, and honors, that Driver must receive points in a minimum of ten (10) INEX Events.

Legend Cars International Dirt Points Series:

Drivers will accumulate points at INEX Sanctioned feature Events competed on dirt. A Driver’s best eighteen (18) finishes plus their best “Nationals Qualifier” Race and their finish at the Dirt “Nationals” Race will count towards their international points standing. This makes a total of Twenty (20) Races (18 Local Races, 1 “Nationals Qualifier” Race and 1 Dirt “Nationals” Race). There shall be a point champion in each of the following divisions: Pro, Master, Semi-Pro, Young Lion, and Golden Master. To receive dirt international Championship awards,

prizes, and honors, that Driver must receive points in a minimum of ten (10) INEX Events.

Legend Cars State Dirt Points Series:

The top Driver in international Dirt points from each state will receive the individual state Championship award. There shall be a state point champion in each of the following divisions: Pro, Masters, Semi-Pro and Young Lions. To receive a dirt state Championship awards, prizes, and honors, that Driver must receive points in a minimum of ten (10) INEX Events.

Legend Cars International Road Course Points Series:

Drivers will accumulate points at INEX Sanctioned feature Events competed on road courses. A Driver's best ten (10) finishes plus their best "Nationals Qualifier" Race and their finish at the Road Course "Nationals" Race will count towards their international points standing. This makes a total of Twelve (12) Races (10 Local Races, 1 "Nationals Qualifier" Race and 1 Road Course "Nationals" Race). There shall be a point champion in each of the following divisions: Pro, Master, Semi-Pro, Young Lion and Golden Master. To receive road course international Championship awards, prizes, and honors, that Driver must receive points in a minimum of ten (10) INEX Events.

Legend Cars State Road Course Points Series:

The top Driver in international Road Course points from each state will receive the individual state Championship award. There shall be a state point champion in each of the following divisions: Pro, Master, Semi-Pro and Young Lion. To receive a road course state Championship awards, prizes, and honors, that Driver must receive points in a minimum of ten (10) INEX Events.

Bandolero National Points Series:

Drivers will accumulate points at INEX Sanctioned feature Events competed in. A Driver's best eighteen (18) finishes plus their best "Nationals Qualifier" Race finish and their finish at the Bandolero "Nationals" Race will count towards their National Points standing. This makes a total of Twenty (20) Races (18 Local Races, 1 "Nationals Qualifier" Race and 1 Bandolero "Nationals" Race). There shall be a point champion for the following divisions: Bandits and Outlaws. To receive international Championship

awards, prizes, and honors, that Driver must receive points in a minimum of ten (10) INEX Events. INEX asphalt, dirt and road course Races all count towards this point Championship.

Bandolero State Point Series:

The top Driver in national points from each state will receive the individual state Championship award. There shall be a state point champion in each of the following divisions: Bandits and Outlaws. To receive a state Championship awards, prizes and honors, that Driver must receive points in a minimum of ten (10) INEX Events.

International:

International Drivers will accumulate points at INEX Events competed in their respective and chosen division. There shall be a point champion from each country (Canada will be split East, Central, West) represented in the INEX International Point System from each division necessary (Pro, Master, Semi-Pro, Young Lion, Outlaw, Bandit). To receive international Championship awards, prizes, and honors, that Driver must receive points in a minimum of ten (10) INEX Events. Only the Driver will receive points, not the car or team owners. A Driver must designate which division they want to receive points on their INEX application.

PROTESTS:

Only current INEX members may protest a component. The Protesting member must show their membership card to submit a protest. Any specific engine, (on a sealed engine, only items not secured by the seals may be protested) rear end, or suspension components of a competitor's car finishing in front of the protestor, may be protested by a Driver and/or Associate Member finishing on the same lap or next respective finishing position of that feature after the Race for the amount designated on the protest fee schedule, payable in cash only.

Protesting back is considered spiteful & is not permitted.

On-track / Race procedure calls cannot be protested to INEX.

Filming or recording of Protest Inspections or close-up photos of the Technical INSPECTION AREA is not allowed.

TIME OF THE PROTEST: The protester's membership card, protest card and full payment in cash only must be presented to the INEX Technical Inspector no later than fifteen (15) minutes from the arrival of the winning car into Inspection Area. The head Technical Official will determine time. Once a protest is submitted, it may not be withdrawn. All purse and points will be distributed after a decision on the protest has been made.

VERIFICATION OF PROTEST: The protested component will be removed from the car or made available for inspection by the protested team's crew and inspected by the INEX Technical Inspector. The following people will be permitted to be present at the Inspection location at the racetrack: protested Driver and/or Associate Member and crew (the crew shall leave once the part is removed), protester, INEX Technical Officials and a Track management representative. If a decision at the Track cannot be made, then the component will be sent to the INEX Technical Director for his sole decision on legality. On a protest, it is the Driver and/or Associate Member's duty to prove his legality, not the Technical Officials or protester's duty to prove the violation.

WHEN THE PROTEST FINDS A LEGAL COMPONENT:

After inspection, if the protested component/part is determined to be legal, the protest money will be given to the Driver of the car from which the component was protested (less reasonable inspection fees and shipping charges if shipped to INEX. Inspection fees & shipping charges will be determined by the INEX Technical Director).

WHEN THE PROTEST FINDS AN ILLEGAL COMPONENT: After inspection, if the protested component is found illegal, the Driver of that car will be Disqualified from that Event, forfeits all prizes and honors earned at the Event and face the possibility of more penalties at the discretion of INEX Competition Director. The Associate Member will be advised, when applicable. The illegal parts will also be confiscated by INEX Technical Inspector. The protest money will be returned to the team filing the protest. The Driver and/or Associate Member who was found illegal will be responsible to pay for inspection fees and shipping charges.

- A car may only be protested by one other competitor at each Event. (If more than one protest is filed against a car, the Driver and/or Associate member with the higher finishing position in that Race will be allowed

- the protest).
- No Driver may file a protest more than 3 times during the calendar year.
 - Protestor must verify that the INEX Technical Inspector has the special equipment necessary for the test, if applicable.

REFUSAL OF A PROTEST: If the Driver and/or Associate Member of the protested car does not allow inspection under these terms, the Driver will be Disqualified, forfeit all points, purse monies, prizes and awards earned at that Event and possibly suffer more penalties as determined by INEX. The car will also be suspended from Competition.

NON-ACCEPTANCE OF A PROTEST by INEX:

The protest may, at the discretion of the INEX Official in charge, be declined if deemed to be malicious or spiteful. INEX Competition Director may also penalize the author of a protest deemed to be malicious, spiteful, or who otherwise acts in bad faith.

Protest Fee Schedule for Legend Cars:

Limited to the choice of one (1) of the following to be protested:

- \$100.00 -1200/1250 Compression Ratio (Choice of any 2 cylinders)
- \$100.00 -1200/1250 Bore Size (Check all 4 cylinders with bore gauge)
- \$100.00 -1200/1250 Stroke
- \$1200.00-1200/1250 Crank Shaft (less than minimum weight / out of engine)
- \$1200.00-1200/1250 Rods (Stock, polished, less than minimum weight / out of engine)
- \$300.00 -Ported & Polished Head (check intake & exhaust)
- \$50.00 -Air Filters (Velocity Stacks and size of filter)
- \$100.00 -Cam Shaft Lobes (check intake & exhaust lobes)
- \$75.00 -Alternator (working & wired properly)
- \$200.00 -Fuel (Specific Gravity Test)
- \$100.00 -Exhaust System (check header and muffler)
- \$100.00 -Total Weight (minimum weight)-Right Side Weight - Rear Weight Percentage
- \$150.00 -Rear End Gears
- \$100.00 -Shocks (each shock)
- \$100.00 -Spindle (Left & Right)
- \$100.00 -Driveshaft (Stock, 14lbs. minimum)
- \$100.00 -Wheel Offset (Check all four wheels)
- \$100.00 -Wheel Weight with Tire (Check all four wheels)
- \$100.00 -Bumper (Front or Rear) meets all specifications.
- \$200.00 -Carburetors / Throttle body
- \$50.00 -Durometer test of tires
- \$100.00 -Engine Seals (Removed in the field by the INEX Inspector and sent to INEX headquarters for inspection. Only if INEX Inspector has replacement seals for re-install).
- \$2000.00 -1200/1250/FZ09/MT09 Engine Inspection (1200/1250 Carburetors/FZ09/MT09 Throttle body, FZ09/MT09 ECU, Alternator, and Starter will be INCLUDED). NOT included; 1200/1250 ignition electrical components, 1200/1250 ignition box, 1200/1250 coils, header, oil cooler, remote filter, radiator, sprocket adaptor, clutch slave cylinder, and air ducts.
- TBD -Reasonable/Comparable fee to be determined by the INEX Official for all other items not specifically listed.

Protest Fee Schedule for Bandolero Cars:

Limited to the choice of one (1) of the following to be protested:

\$50.00 -Air Filters

\$100.00 -Rev Limiter

\$200.00 -Fuel (Laboratory Test)

\$150.00 -Exhaust System (check header and/or muffler)

\$100.00 -Total Weight (minimum weight)

\$100.00 -Rear Axle

\$150.00 -Shocks (Check rear shocks)

\$150.00 -Spindle (Left & Right)

\$100.00 -Wheels

\$100.00 -Front Bumper or Rear Bumper meets all specifications

\$200.00 -Carburetor

\$50.00 -Durometer test of tires

\$100.00 -Engine Seals (Removed in the field by the INEX Inspector and sent to INEX headquarters for inspection. Only if inspector has replacement seals for re-install).

\$500.00 -Engine Inspection (Engine, including carburetor AND intact restrictor plate, – Top to bottom. Un-plug wires, throttle cable, fuel line. Remove headers, clutch. Un-bolt engine and ship to INEX) INEX Inspector will oversee shipment of engine.

TBD -Reasonable/Comparable fee to be determined by the INEX Official for all other items not specifically listed.



COMPONENT PROTEST CARD

Only current INEX members may protest a component. You Must present an INEX membership card for acceptance of the Protest.

Any specific component (that is not secured by an USLCl Engine Shop seal), rear end or suspension components of a competitor's car finishing in front of the protestor, may be protested by an INEX member finishing on the same lap or respective finishing position of that feature after the Race for the amount specified on the protest fee schedule in the current INEX rulebook, in the form of cash only.

TIME OF THE PROTEST: The protest card and full payment in cash must be presented to the INEX Technical Inspector (or INEX representative) no later than fifteen (15) minutes from the arrival of the winning car into technical inspection area. The head Technical Official will determine Time. Once a protest is made, it may not be withdrawn.

REMOVING THE PROTESTED COMPONENT: The protested component will be removed from the car (or made ready for inspection) by the protested teams crew and then inspected by the INEX inspector (or INEX representative). If a decision at the Track cannot be made, then the component will be sent to INEX for a final decision on legality of the component.

IF THE COMPONENT IS FOUND ILLEGAL: The Driver of that car will be disqualified from that Event and face the possibility of further penalties at the discretion of INEX Technical Director. The protest money will be returned to the member submitting the protest.

IF THE COMPONENT IS FOUND LEGAL: The protest fee will be given to the car owner who owns the protested component (less applicable inspection fees & shipping charges).

DRIVER INFORMATION (Required)

Series: _____

Protester's Name: _____

INEX Membership #: _____

Feature Finishing Position: _____

Driver (Protested) Name: _____

INEX Membership #: _____

Feature Finishing Position: _____

INEX INSPECTION INFORMATION

Chassis # (If Necessary): _____

Engine # (If Necessary): _____

Date: _____

Time: _____

Track: _____

INEX Official: _____

Notes: _____

BACK OF PROTEST CARD (BLANK)

PERSONAL (DRIVER) SAFETY EQUIPMENT:

No express or implied warranty of safety shall result from publication of, or compliance with these rules and regulations. They are intended as a guide for the conduct of the sport and are in no way a guarantee against INJURY or DEATH to participants, spectators, or others. Whenever there is a conflict between a safety provision provided herein and any other rule, the safety provision shall take precedence.

INEX Technical Inspector may in their sole judgment dis-allow the use of any safety equipment that they consider to be any of the following: not in proper working condition, out of date, damaged, tore or ripped and substandard.

1. HELMET: Drivers must wear a full-face helmet, of current standards of 2015 or newer Snell SA rating or S.F.I. 24.1 rating, any time they are on track. Snell "M" rated helmets are not permitted. Helmets are subject to inspection at each Event by the technical inspector or other Official. Helmet shields are required.

NOTE: A helmet is designed to absorb energy once. If a significant impact has occurred to the helmet, it is highly recommended that it be sent back to the manufacturer for evaluation.

2. FIRE SUITS: Drivers must wear an INEX-approved fire-retardant suit of Nomex or equivalent material any time they are in Competition. Fire suits must be made and labeled as Flame retardant (or have a S.F.I. specification patch). A double layer fire suit is highly recommended.

3. FIRE RETARDANT GLOVES: Fire retardant gloves usage is mandatory during all on-track activities. Gloves must have "SFI approved" tag or wording included on care label stating that they are flame retardant.

4. SAFETY HARNESS: Cars must have an INEX-approved type of five-or six-point racing harness that is equipped with a quick release buckle. INEX endorses (not requires) the belt manufacturer's recommendation that the belts be changed two (2) years after the manufacture date stamped on the SFI tag regardless of the number of times the car has been Raced.

IMPORTANT NOTE: Be sure to regularly check your seat belts for damage such as fraying, tearing, etc. If this should occur, the seat belts should be replaced

immediately. The seat belts are like the helmet usage suggestions, in that they are designed for protection in only one major impact. If you have had a significant incident, the manufacturer strongly recommends immediate replacement of the belts. Also, make sure that your harnesses are secured and that you have pulled the straps as tight as possible anytime you drive the car. Continue to retighten the harnesses under caution.

5. FIRE EXTINGUISHERS: An on-board fire extinguisher system is highly recommended for your safety. When installed, the fire extinguisher must be operational. The spirit of this rule is for safety, not for ballast. When the fire bottle's weight is greater than nine pounds, written approval from the INEX Technical Director is required.

Fire suppression systems only will be permitted. Hand held fire bottles are not allowed.

6. RACING SHOES: Drivers must wear fire retardant racing shoes; usage is mandatory during all on-track activities. Shoes must have "SFI approved" tag or wording included on care label stating that they are flame retardant.

7. ROLL BAR PADDING: Roll bar padding (SFI-45.1) on all bars within one foot of Driver's helmet is mandatory.

8. SEATS: Only INEX-approved, purpose built (circle track or road course racing), factory-manufactured Aluminum or Carbon Fiber seats may be used. Carbon Fiber seats must adhere to the design specifications of the S.F.I. 39.2 or S.F.I. 39.1 certified seat construction standards. Carbon fiber seats must have a current, valid S.F.I. 39.2 or S.F.I. 39.1 certification and have the official S.F.I. sticker affixed to the seat to show proof of this certification. All seats must be used and installed following the instructions provided by the seat manufacturer. If the seat is designed to incorporate the harness system mounting, this must also follow the instructions provided by the seat manufacturer. Homemade seats are not permitted. Weight reduction outside of the manufacturers design and any seats modified from the manufacturers design are not permitted.

9. INEX APPROVED HEAD AND NECK RESTRAINT SYSTEMS USAGE IS MANDATORY.

10. Mounting of the Seat in a Legend Car -The seat may be moved within the driver's compartment without moving or changing existing bars in the frame. The centerline of the seat must be a minimum

of 10" from the left side of the roll cage. When mounting the seat forward, use a flat piece of steel or aluminum behind the seat (not bolts in tubing). The use of wood as supports or mounting brackets is not permitted. Hardware used to mount seat must be a minimum of 3/8" grade 5 bolts.

Bolts required = Two bolts through the seat and the seat back of the chassis and two bolts attaching the base of the seat to the original seat tabs or directly to the 1" X 2" square tubing that the original seat tabs were welded to. Bolting the base of the seat to the floorpan only will not be permitted.

10. Mounting of the Seat in a Bandolero Car-The centerline of the Bandolero Seat must remain within a quarter (1/4") inch of the centerline of the car. Verify that the Driver's helmet, when seated in the car, does not extend beyond 1" from the bottom of the top roof bar of the roll cage. Hardware used to mount seat must be a minimum of 3/8" grade 5 bolts. All Bandoleros must have some form of lateral support added to the seat back.

11. OTHER SUGGESTED SAFETY EQUIPMENT:

These items are not required, but they are all highly recommended. (An individual Track may require them).

- 1.) Flame retardant underwear and socks.
- 2.) Head sock (balaclava).
- 3.) Steering wheel pad.
- 4.) Arm restraints.
- 5.) Helmet supports on the seat.
- 6.) Interior door padding and tunnel padding.

ADDITIONAL PERSONAL SAFETY & RACE EQUIPMENT REQUIRED BY INDIVIDUAL STATE/ COUNTRY, TRACK, ASSOCIATION or EVENT SPECIFIC RULES:

Individual states, countries, associations, Tracks, and/ or special Races may have specific rules, in place, for their Events. Changes and /or additions may be necessary to your car and/or safety equipment. You should check with the Track you are planning on attending prior to the Event(s) Competition.

NEW JERSEY STATE REQUIREMENTS:

The following modifications to a Legend Car are required to Race in New Jersey:

- 1.) Steel plates welded onto existing passenger side door.
- 2.) Nomex boot attached to seatback covering the existing safety harness hole.
- 3.) An approved Fuel shut off switch must be located on the top shelf behind Driver's right shoulder on flat sheet metal. Switch must be marked ON/OFF.

- 4.) Plastic battery box.
- 5.) Pad on steering wheel.
- 6.) Remove threaded rods on existing fuel cell bars and replace with 5/16" bolts through fuel cell bar. Bushings must be installed in holes drilled for new bolts passing through fuel cell bars.
- 7.) Add to the door strike plates with 3/16" thick, 1-1/2" x 1-1/2" angle iron that is 5" in length. Weld the angle iron on each door strike plate so that the angle iron prevents the door from closing in towards the Driver.

SCCA (Sports Car Club of America) REQUIREMENTS:

SCCA may require the following modifications to a Legend Car to participate in an SCCA-Sanctioned Regional Racing Event:

- 1.) Cars shall have two (2) red brake lights per GCR Sect. 12.19 within minimum fifteen (15) watt bulbs.
- 2.) Engine breather shall be equipped with oil catch tank per GCR Sect. 12.25. The oil catch tank capacity shall be one (1) U.S. Quart maximum.
- 3.) All cars shall be equipped with a master electrical cut-off switch (per GCR Sect. 12.26) easily accessible from outside the car. It should be in the rear window just behind the "B" post on the right.
- 4.) All cars are required an on-board fire system per GCR Sect. 12.22.1.
- 5.) *All cars shall be equipped with a five (5) gallon metal fuel cell*
- 6.) All suspension Heim joints shall be captured with a flat washer.
- 7.) Arm restraints or window nets are required.
- 8.) A current INEX Rulebook is required to be in possession of each entrant.
- 9.) All cars must be certified, approved for competition and fee to be paid through SCCA. For more information about the Sports Car Club of America, contact them at (303) 694-7223.

RAC (UNITED KINGDOM) REQUIREMENTS:

The following modifications to a Legend Car are required to Race a RAC-Sanctioned Race in the United Kingdom:

- 1.) A rearward facing red warning light as specified in Q5 (for bad weather) must be positioned at the rear, below the line of the back window and above the trunk compartment lid.
- 2.) An external electrical cut-off switch must be positioned behind the Drivers shoulder and clearly marked with and on and off.
- 3.) The standard seat belt racing harness must be fixed to points in accordance with UK/Mod. 96-2. Contact Legend Racing Europe for specifications of these points.

- 4.) The front bulkhead and rear compartment containing the fuel cell must be completely isolated from the driver's compartment.
- 5.) A double layer racing suit is the minimum acceptable.
- 6.) A fire extinguisher (minimum 2.5kg BCF recommended) must be fitted and securely fixed within the driver's compartment.
- 7.) Protective padding must be applied and securely fixed to those parts of the roll cage with which the Driver's body or helmet come into contact.
- 8.) Towing points at the front and the rear must be fixed to the front and rear frame rails, in accordance with UK/Mod. 96-3 (contact Legend Racing Europe for specifications) and they must be indicated by yellow paint (or a clearly visible contrasting color) and the word "Tow."
- 9.) Netting is recommended in the rear side windows of sedan models and in the door windows of coupe models, or, alternatively, in sedan and coupe models, a seat fitted with approved side head restraints.
- 10.) Exhaust System as specified by Legend Racing Europe.
- 11.) Reverse Gear as specified by Legend Racing Europe.
- 12.) OVAL RACING IN THE UNITED KINGDOM:
The rules for oval racing in the United Kingdom are the same as the United States standards except for the required use of the modified exhaust system (#10 above).

FUEL REQUIREMENTS

INEX reserves the right to require all cars use the same brand and designated grades of gasoline in each Event.

12. LEGEND CAR FUEL:

Only petroleum-based unleaded or leaded gasoline as defined by the American Society of Testing and Materials (ASTM) is permitted. The only oxygenates permitted are MTBE and ethanol alcohol in the same levels as that are found in pump gasoline.

13. BANDOLERO CAR FUEL:

Only petroleum-based unleaded or leaded gasoline as defined by the American Society of Testing and Materials (ASTM) is permitted. The only oxygenates permitted are MTBE and ethanol alcohol in the same levels as that are found in pump gasoline.

Specific Gravity -The specific gravity must fall between .700 to .770 at 60 degrees Fahrenheit.

Laboratory Testing -INEX may conduct laboratory

analysis of fuels. Samples for lab analysis may be taken from a competitor's fuel tank at any time at the discretion of INEX.

The specific elements which will be searched for include: propylene oxide, alcohols (all types), aldehydes, aminodiphenyl, benzene (in excess of EPA limit), benzidine, beryllium compounds, bromine compounds, butadienes, chlorinated compounds, chromates, dioxanes, ethyl acrylate, ethylene oxide, hydrazine compounds, methylene dianiline, naphthylamine, nitrogen compounds (nitromethane, et al.), styrenes, toluidine and xylidine. Also added to this list will be substances deemed to exceed the Threshold Limit Values (TLV) or Biological Exposure Indices (BEI) as listed by the American Conference of Governmental Industrial Hygienists (ACGIH).

FUEL ADDITIVES:

Over the counter lubrication or knock suppression additives are permitted, provided the resulting mixture meets the specific gravity and lab analysis requirements.

Penalty for Fuel Rule violations - Any Competitor (Driver and/or Associate Member) caught using any of the illegal fuel additives as previously mentioned may be subject to a suspension, fine, and cost of fuel test(s). Penalties will be determined by the INEX Competition Director.



LEGENDS CAR SPECIFICATION RULES

If this rulebook does not specifically say that you can change/modify/add something, then you must consider that the change/modification/addition is illegal.

Any questions about the legality of a change/modification/addition not covered in this rulebook must be submitted to and answered by INEX Technical Director in writing and presented to the INEX Technical Inspector upon request.

No equipment or Racecar will be considered as having been approved by reason of having passed through inspection unobserved. Regardless of Legend Car passing prior inspections, compliance with all rules must be made at each post-Race inspection. No expressed or implied warranty of safety shall result from the technical inspection or approval.

FRAMES, BODY and SUSPENSION COMPONENTS:

1. AERODYNAMICS: Spoilers, air dams or other aerodynamic devices as determined by INEX are not permitted.

2. AIR FILTERS: Only stock USLCI, K & N air filters and Outerwear's Pre-Filters coverings are permitted. Velocity/ram stacks are not permitted. No components that direct airflow to the carburetors or increase airflow are permitted.

3. ALTERNATOR: Modification(s) to the charging system is not permitted. The alternator system must always be charging. No switches that disconnect the alternator from the charging system are permitted.

4. BALL JOINTS: *Upper and lower ball joints must remain Stock, within the Stock dimensions, steel thickness, location and configurations and may not be reinforced. One or two (minimum 1/4", maximum 7/16" width) jam nuts are permitted on the upper and lower ball joints. Each ball joint must use a minimum of one jam nut. Jam nut(s) may not be welded to control arms. Limiting the natural travel of the ball joints is not permitted.*

5. BALLAST: A maximum of eight (8) blocks of solid lead ballast are permitted on the car. (E.I.R.I.) The blocks may be no larger than 1-1/2" x 2-1/2" x 12" (approximately 20 lbs.). Stacking of blocks of any size is not permitted. All ballast must be visible with white or bright paint/tape and identified with the car number. Ballast must be lead only and may not be added by any other method, including steel shot or any other material in the frame rails, bumpers, nerf bars or any other component.

Mounting Ballast -The ballast blocks must be bolted directly to the sub-frame and must be secured with a minimum of two (2) 3/8" Grade 5 bolts for EACH piece of lead. Ballast may be bolted to the square tubing of the sub-frame from the front to the back (including the cross members) (1" X 2" tubing only), not to the roll cage. The blocks must not be encased in any way. The ballast must maintain a minimum of 3 1/2" inches of ground clearance. Ballast must not extend past the front frame horns or rear bumper mounts or extend beyond the subframe at the kick ups. Ballast is not permitted to be mounted inside the driver's compartment. No ballast may be bolted to the running board or the nerf bars. Ballast may not extend laterally, beyond 2 1/2" from the outside of the frame rail. All mounting of the ballast must be approved by the INEX Technical Inspector.
Any "Driver cooling system" equipment must be mounted on the right side of the car.

6. BATTERY: A single lead acid or gel cell battery (a minimum weight of 20 lbs.) or the US Legend Cars International Feather – Lite, Lithium Battery or the ANTIGRAVITY battery (as delivered by US Legends Cars International) is permitted. A top post or side post battery may be used. Motorcycle batteries may not be used. The battery must be secure and mounted in the Stock location. *The original Stock battery bracket may not be altered. Starter solenoid must be mounted on the battery bracket when using the 1250 engine.* A battery box, terminal coverings or rubber padding around rear end is also highly recommended. A battery shut-off switch is optional.

Legends Battery Box Offset

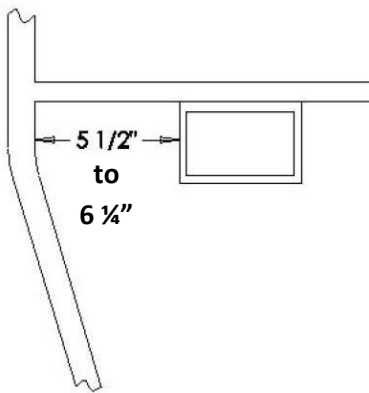

Note: The measurement for the battery box offset will be taken at the point closest to the crossmember, from the inside of the framerrail to the outside of the battery box.

7. BOLTS AND FASTENERS: Only equivalent Stock or upgraded steel fasteners and bolts may be used on the car. Fasteners may be drilled for safety wire, however intentional weight saving modifications are not permitted. All bolts must be magnetic. Aluminum and titanium or composite material bolts are illegal. INEX Technical Inspector must be able to identify the grade of bolt.

8. BRAKES: *Any of the brake parts that are attached to the rear end or the spindles must remain Stock, within the Stock dimensions, steel thickness, location, and configurations.* Willwood brake calipers are permitted as delivered by USLCI. Brake calipers must be mounted on the back side of the rotors. The car must have operational brakes on all four wheels and must lock up all four wheels during inspections (Brake lines may not be plugged or shut off). Any type of brake cooling duct is not permitted. The right or left side brake pedal may be removed. Brake line quick disconnects are not permitted.

Brake Rotors -Only stock steel rotors (not reduced in diameter) are permitted. As delivered by US Legend Cars International. The minimum thickness of a brake rotor is 8mm.

Brake Drums -Stock Steel drums (not drilled or lightened) are permitted on the rear. The minimum weight of the brake drum is 10.0 lbs. Removal of metal from the brake drum for lightening purposes or "offset" is not permitted. Only the "shoe face" may be machined.

Legends Brake Drum

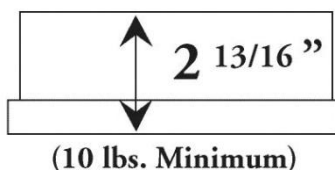

Brake & Clutch Lines -Rubber, hardline or steel-braided brake and clutch lines are permitted. No brake lines may be disconnected or plugged.

Brake Master Cylinder -*The brake master cylinder must remain Stock, within the Stock dimensions, location configurations and must remain on the engine side of the firewall. Aftermarket remote reservoirs are permitted.*

Brake Proportion Valves -Only one brake valve or, residual valve or pressure valve will be permitted in a car using the rear drum brake system. Cars using the rear disc brake system are permitted to use an additional brake valve, residual valve or pressure valve to regulate brake pressure to the rear brakes. Complete elimination of the brake pressure at any wheel is not permitted.

9. BUMP STEER: Adjustments to bump steer settings will only be permitted by placing spacers between the steering rack and the Heim joint ends of the tie rods or between the front spindle pick-up points and the Heim joint ends of the tie rods. No other modifications to adjust bump steer such as changing the height of the steering rack or modifying the spindles are permitted.

10. BUMPERS: Front Bumper -*The front bumper must remain within the Stock dimensions, steel thickness, location, and configurations and must not be reinforced, except for adding one (1) additional bolt per front and/or rear frame rail to the tab.*

Legends Front & Rear Bumper

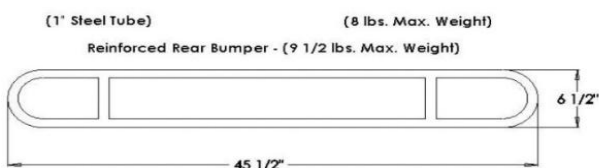

Rear Bumper -*The rear bumper must remain within the Stock dimensions, steel thickness, location, and configurations. The rear bumper may be reinforced*

by attaching tubular steel from the bumper to the rear frame horns. One (1) additional bolt per frame rail to the tab is permitted. If reinforced, the steel tubing (12" maximum length) may not extend beyond the outside width of the rear bumper or attach to the rear cross member of the frame.

Attachment of the Bumper – Bumper tabs must use a minimum of one bolt per tab securing the bumper. There must be a minimum of 1" from the end of the frame rail to the back of the bumper upright before a Race begins. Should the tab become bent during a Race, it must be fixed before the next time the car goes on the track to compete. Tie-wraps, safety wire, duct tape, etc., are not permitted to secure the front or rear bumpers or bumper tabs.

Bumper Tabs - *The bumper tabs must be Stock.* And must be .125" - .140" in thickness. Tabs with excessive weld will not be permitted.

Repairing a bumper During a Race: Bumpers are mandatory throughout the Race and must be bolted on in approved manner. Tie-wraps, safety wire, duct tape, etc., are not permitted to repair the bumper(s). An INEX Technical Inspector will disqualify a Driver after a Race if the repaired bumper violates this rule.

NOTE: Race Procedure/ Bumpers are Mandatory
A car must compete with both bumpers that are not in contact with the track or considered in a dangerous position or condition by Track Officials at any time. If any of these conditions are not met, Track Officials may black flag the car.

NOTE: The INEX Technical Inspector does not have the authority to disqualify a Driver after the Race for a violation of this Race procedure.

11. CARBON FIBER: Carbon fiber component usage is not permitted.

12. 1200 / 1250 CARBURETORS: *The carburetors and components of the carburetors must remain as Stock Yamaha FJ1200/ XJ1200/XJR1250 (sealed).* Only carburetor jets, needles, slide springs and butterfly screws may be replaced. Butterfly screws may only be replaced with 3mm X 6mm Allen head screws or Stock screws. These screws must not be altered in any way other than "stamping" the end to secure the screw. *All Stock adjusters may be used. No other modifications to the carburetors permitted.*

Modifications or components to increase or restrict airflow or fuel flow (such as velocity stacks, heat deflector shields, internal modifications not listed above, etc.) are not permitted.

13. CHROME PLATING/POLISHING: External parts such as bumpers, nerf bars, suspension components and cam cover may be chrome plated or polished.

14. CLUTCH MASTER CYLINDER: *The clutch master cylinder must remain Stock, within the Stock dimensions, location and configurations and the clutch master cylinder and reservoir must remain on the engine side of the firewall. No Aftermarket clutch master cylinders are permitted. The clutch pedal length may be shortened for Driver comfort.*

15. CONTINGENCY SPONSOR DECALS: Contingency sponsor decals are optional. To be eligible for posted awards from the contingency sponsor, decals are mandatory and /or use of the product.

16. DOOR PLATES: *The use of a door plate on the Driver's side door is mandatory. Doorplates and strike plates must meet specifications of USLCI. The door plate is permitted to be added to the right-side door. A competitor may use a doorplate covering the entire door area on either side of the car (maximum of 1/8" thick).*

17. DRIVESHAFT: *The driveshaft, flanges, and u-joints and all components of the driveshaft must remain within the Stock dimensions, steel thickness, location, weight (14 lbs. minimum) and configurations USLCI. The driveshaft must be painted white or light gray.*

Driveshaft Retainers -INEX-approved driveshaft retainer strap is permitted. A maximum of three (3) retainers of 1/4" thickness and 3/4" width is permitted. Requests for additional retainers for the driveshaft must be submitted to and approved by the INEX Technical Director in writing.

18. ENGINE COATINGS: Only engine coatings as delivered Stock from the factory are permitted. Removal of any engine coatings is not permitted. Headers may be painted with high heat paint only. (Header wrap tape is permitted.) Repainting the outside of the engine or using an unpainted engine is permitted.

19. 1200 / 1250 ENGINE COOLING: Additional fan(s), internal duct work, hood louvers, remote oil filter, header wrap, holes in the hood, holes in the front fenders and/or oil coolers are permitted. The maximum height for louvers is 3/8". The size of the area for louvers or holes in the hood may not exceed 54 square inches (9" x 6"). These components may not direct air to the carburetors or air filters.

20. ENGINE SERIAL NUMBER: All engine casings must have a serial number.

21. 1200 / 1250 ENGINE LOCATION & MOUNTS: *Left and right-side engine mounts must remain within the Stock dimensions, steel thickness (no aluminum mounts), location and configurations. The right-side motor mount may be replaced with the optional motor mount (if the optional right-side mount is used; you may remove the Stock right side mounting tabs).* Rubber mounts will be permitted if the engine remains in the Stock location. The engine mounts must be bolted on to the frame as specified by USLCI. Mounts may not be welded directly to the frame.

Legends Right Side Motor Mount

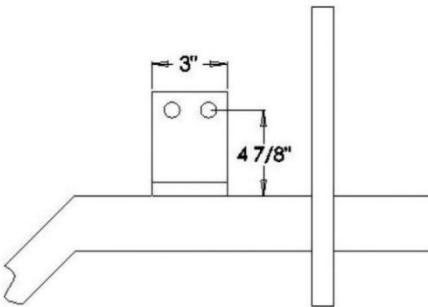

Aluminum mounts or extra holes are illegal.

Legends Left Side Motor Mount

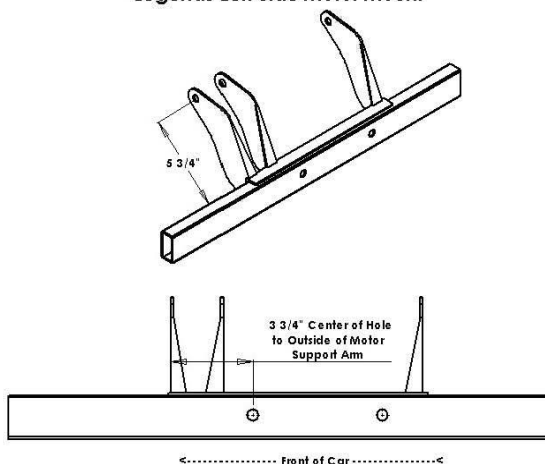

22. EXHAUST SYSTEM: *The header, muffler and gasket must remain within the Stock dimensions, steel thickness, location, and configurations of the original. Extra tabs, safety wire etc. are permitted to secure the muffler. Mufflers may not be completely welded to the pipes. The internal components of the header and muffler may not be altered. Header wrapping (tape) is permitted. Ceramic or baked on coatings are not permitted. Stock, INEX approved Borla and S&S exhaust systems (as delivered by USLCI) are mandatory for use with Yamaha 1200 or 1250 from USLCI. ProFab exhaust system (as delivered by USLCI) is mandatory for use with Yamaha FZ09.*

23. FENDER MOUNTING: *Stock fender mounts may not be altered. No additional fender supports, or mounts are permitted (only Stock mounts may be used). All '37 Ford style grills must use the inner mounting hole (closest to the grill). Dzus fasteners may be used for fender removal purposes only. Cars that use a fiberglass grill shell may remove the original fender brackets.*

Area under the Rear Fenders -Removal of the fiberglass panel on the body under the rear fenders is permitted for access to the shocks, springs and rear compartments.

24. FENDER HOLES & TRIMMING OF FENDERS:

The holes and trimming that is permitted:

Holes -Maximum of ten (10) hole(s) per fender. Maximum hole(s) is four (4) inches in diameter. Any shaped hole(s) equal to or less than the area of a 4" round hole is permitted.

Note: a four-inch hole saw will produce a hole larger than four inches)

Trimming of Fenders-

Front Fenders -The only trimming of the front fenders allowed is on the inside edge of the fender starting 12" above the frame rail on the front clip, along the contour of the fender, and only trimmed in 3" from the edge, back to the firewall.

The inside of the fenders near the grille, the edge of the fenders near the body shell (past the firewall), the outside of the front fenders and the bottom edge of the front of the fender may not be trimmed.

Rear Fenders -Rear fenders may be trimmed **above the tire** for additional clearance. The rear fender contour must measure at least nine (9) inches from the main body shell. Measurements will be taken at the point on either rear fender above top dead center of the tire. No holes or other trimming is permitted in the rear fenders or body shell.

25. FIBERGLASS BODY COMPONENTS: *All fiberglass body components must remain within the Stock dimensions, thickness, location, and configurations. All fiberglass components must have an authentic INEX certificate embedded into the underside of the fiberglass component, evidencing that the component is a certified USCLI part.*

Fiberglass components may not be reinforced or lightened in any manner. The use of a complete front end (Matching hood, fenders, grill, and grill shell) on a different model car is acceptable. All cars may use 34 Ford rear fenders.

Mounting of Body Components -All fiberglass body components must be firmly attached to the Car competing in any Race. It is recommended that all Dzus fasteners fit tight and are taped over to prevent loosening.

Rear of body may be trimmed between the frame rails up to the top edge of the rear frame horns. Body may be riveted along the side of the sub-frame. The original body mounts are not permitted to be higher than the top of the sub-frame.

Removal of undamaged fiberglass body components (hood, deck lid, etc.) during an Event is not permitted. Any car may be black flagged or denied entry to start a Race if any of the aforementioned items are not attached, unless prior approval is given by the INEX Technical Inspector.

26. FIREWALL: *An aluminum firewall is mandatory. Firewall must be configured as delivered by USLCL. Using a "thicker than Stock" aluminum firewall*

separating the driver's compartment from the engine compartment is permitted.

27. FRAME: *No modifications of the frame (including roll cage) will be permitted unless otherwise noted in this rulebook. All frames must have I.D.*

(Identification) plate secured on the frame. No weight reduction of the frame (including roll cage) is permitted. Any other requested chassis modifications or repairs are only permitted with a letter from the INEX Technical Director.

Frames with a 0.065" electric resistance welded main roll cage are not allowed. Frames with a 0.083" drawn over mandrel main roll cage are required. It is estimated that all frames produced before August 1995 do not meet the above 0.083" drawn over mandrel requirements.

Suicide Doors -Doors with the latch on the A-Pillar and hinges on the B-Pillar rather than the traditional method of the latch on the B-Pillar and the hinges on the A-Pillar. Suicide doors are only permitted on the 1934 Ford and Chevy Coupe frame.

Serial Number Plates - Frame's competing must be manufactured by USLCI. The serial number assigned to that frame can be found on the Vehicle Identification Number plate. This plate shall not be tampered with in any way.

Metal Fatigue -It is recommended to have the frame checked periodically by an expert for metal fatigue. Cracked or broken frames are prohibited from any INEX Events.

28. FRAME REPLACEMENT: *If the chassis should become severely damaged, replacement frames must be obtained through USLCI or its authorized dealer network.*

29. FRAME REPAIR: *Only front or rear clips may be replaced with the exact material that it is replacing, and all pick-up points must remain in the Stock locations as delivered new from USLCI. The clips may be purchased through USLCI or its dealer network. The driver's compartment of the frame (roll bars, cross braces, etc.) may not be repaired or replaced if damaged (see rule #28 above). The INEX Technical Inspector reserves the right to disallow a repaired car from Competition that is not properly repaired. Once a frame is repaired from its original form, INEX, USLCI and the INEX Technical Inspector assume no liability for any injuries that may occur because of this repair regardless of the approval given to compete with that repaired frame.*

**Legends Left Side Motor Mount
Pickup Points & Front Clip Measurements**

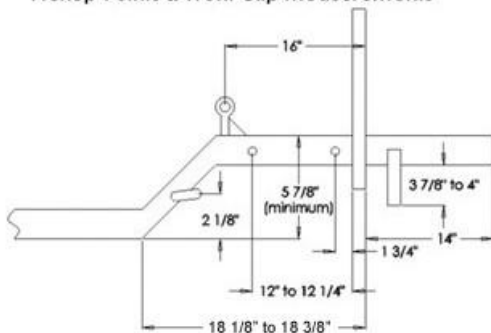

30. FUEL CELL: *INEX-approved fuel cells (plastic or metal) must be Stock and must remain in the Stock location.* Metal fuel cells must be bolted through bolt holes in steel can. The red plastic fuel cell with the 5 5/8" diameter cap or larger is not allowed.

Fuel Cap -Check the cap on your fuel cell for tightness before going on the track. The fuel cap should fit snugly into the cell. The car number must appear on fuel cell cap. INEX approved, Aftermarket racing fuel caps are permitted.

Fuel Cooling Devices -Fuel cooling devices of any kind are not permitted on the car at any time.

31. FUEL FILTER: Aftermarket fuel filter may be used. No glass fuel filter will be permitted. The Fuel filter is not permitted in the engine compartment.

32. FUEL LINE: Fuel lines are not permitted to run through the driver's compartment. Steel braided or Kevlar braided fuel line is mandatory. The fuel line may not be attached to or contact electrical wires.

33. FUEL SHUT-OFF VALVE or FUEL REGULATOR: Aftermarket fuel shut-off valves and fuel regulators are permitted and must be marked for the "Off" position.

34. GAUGES: Analog Gauges that record or display the following information only are permitted; cylinder head temperature, RPM, oil pressure and oil temperature. Digital gauges are not permitted except for Stock gear indicators, Longacre and Intercomp lap timers, Lapceivers (By RACEceivers), Fastach Digital Tach (By SenDec, Corp.) and the Koso gauge as delivered by USLCI. Digital gauges not

available through USLCI are not legal for use during any INEX sanctioned event. If a car is found with a gauge that violates this rule during qualifying, heat races, B-main or the main event, the gauge will be confiscated and the car will be disqualified from the event it was used in. If the gauge is found during raceday practice, the gauge will be confiscated. No other information to include, but not limited to, wheel spin, shock travel, exhaust gas temperature, throttle position or G-force, will be allowed at any time. Onboard telemetry systems are not permitted. Direct reading oil temperature and oil pressure gauges must use steel braided lines.

35. GEAR RATIOS: *Only rear end gear ratios from a 2:50 to 4.30 are permitted. The gears must remain within the Stock dimensions, steel thickness, location, and configurations.* “Tumbling”, polishing, sanding, etc. of the ring & pinion gears is not permitted.

36. GENERAL APPEARANCE OF THE CAR: All competitors must present a neat, clean, and Stock appearing car for Competition. Crash damaged cars must be repaired to the minimum technical standards before returning to Competition. An INEX Official may deny a car from competing if it does not meet the minimum acceptable standards as mentioned above. INEX reserves the right to deny access in Competition because of a sponsorship, advertisement, paint scheme and/or lettering on a car not in “good taste,” or in the spirit of keeping this a family sport.

37. GRILL: *The steel grill must remain within the Stock dimensions, height, steel thickness, location, and configurations and may not be reinforced in any way.* The grill used must be the same model of the hood, grill shell & front fenders that are used. Grill brackets (to the frame) must remain Stock. Altering the brackets to raise or lower the grill is not permitted. Only wire screens are permitted to enclose the grill area (i.e. for dirt tracks to keep out mud and dirt). Duct tape or any other type of material other than a wire screen is not permitted to enclose the grill area. The radiator can be “taped off”. The grill cannot be “taped off”.

38. GUSSETS: Strengthening gussets may only be added in the locations as described in the Diagrams below. No Stock gussets may be removed.

Front Clip Support

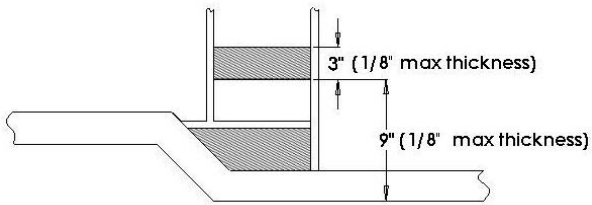

Upper Link & Rear Trailing Arm Pickup Points

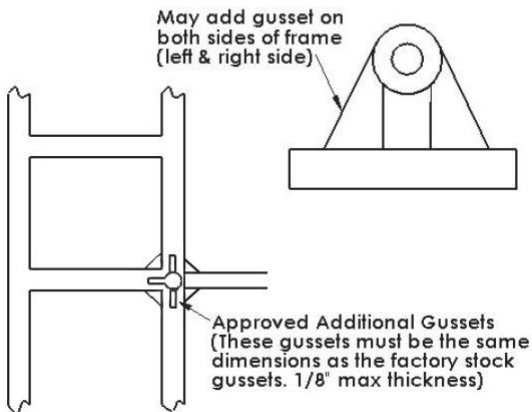

Rear End Housing Upper Link & Rear Trailing Arm Pickup Point

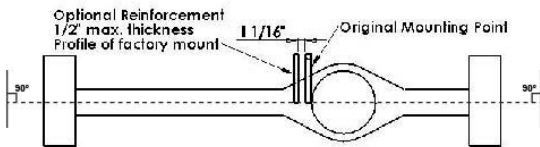

(This reinforcement will secure the opposite side of the rod end of the upper link)

Back View of Housing

Approved Rear Gussets (Max. 3/16" thick)

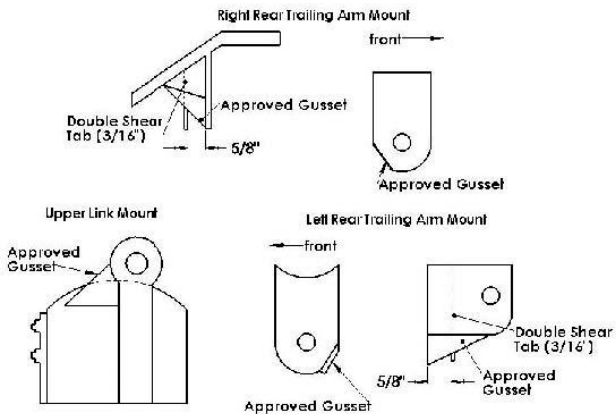

Steering Rack Plate

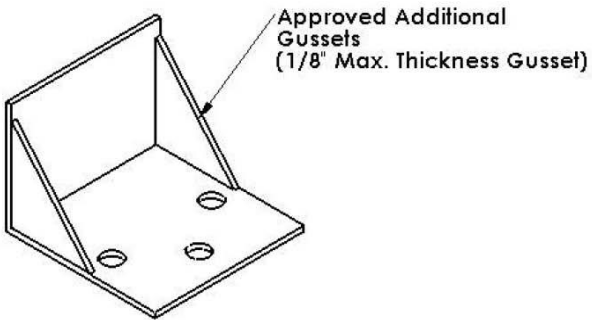

Upper Link Double Shear Mount (Chassis Side)

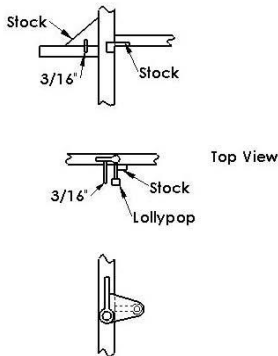

39. HEIM JOINT ENDS: Only magnetic steel Heims of similar dimensions as delivered new by USLCI permitted.

NOTE: The Stock Heims joints are designed to bend/break and absorb energy under impact. Heims joints may be upgraded, however under impact, the upgraded Heims joints may not bend or break as quickly thereby transferring the impact-energy to the driver and an injury may result (i.e. broken wrist from the transfer of energy).

40. HOOD: Hood louvers are permitted a maximum 3/8" in height. Louvers or holes in the hood may not exceed 54 Square inches. Replacing the Dzus fasteners located on the rear of the hood with hood pins is permitted. Raising the rear of the hood on the rear pins a MAXIMUM of 1" is permitted. While the car is on the track, the hood must be secure and may not move up or down on the pins. Hood louvers may not direct air to the carburetors or air filters. Air ducts may be used, mounted underneath inside the hood. The duct is not permitted to direct airflow onto the carburetors or air filters.

Hood Lengths: The minimum length permitted for 1934 Chevy and Ford hoods is 26" (measured down the middle). The minimum length permitted for 1937 Chevy and Ford hoods is 32" (measured down the middle). When using the FZ09 engine, the air filter may stick through the hood.

41. IGNITION SYSTEM: *The complete ignition/engine control system must be the original OEM parts for the Yamaha FJ1200/XJR1200/XJR1250/FZ09/MT09. In-line fuses are permitted. Ignition pickup coil wires must run directly to the ignition box and may not be taped, or tie wrapped to other wires. No open wires or unused connectors allowed within reach of the Driver.*

Electronic throttle (traction) controls are not permitted.

Ignition Control box -*The Stock FJ1200/XJR1200/XJR1250 ignition control box (black box) or the red ignition box (marked INEX-Approved) are the only boxes permitted to be used with the 1200 + 1250 engine and they may not be altered or relocated in any way. Only one ignition box is permitted on a car (multiple boxes are illegal). The original Stock FJ1200/XJR1200/XJR1250 rev limiting system must be in proper working condition and may not exceed 10,500 rpm. The FZ09/MT09 must use the ignition control box (ECU) designed for use with that engine.*

Swapping of the Ignition Control box -*INEX may provide a substitute ignition/engine control system to any competitor at random. The INEX provided ignition/engine control system will be exchanged for a Competitors system and must be used for that Event. INEX is not responsible for any engine failure due to a provided ignition/engine control system usage.*

Coil, Coil Wires and Spark Plug boots -These components must be Stock Yamaha FJ1200/XJR1200/ XJR1250 parts, Taylor coil wires or gray Dynatek coil wires or red Dynatek coils marked with the INEX logo as delivered by USLCI. *The FZ09/MT09 components must remain Stock.* The spark plugs may be replaced with an Aftermarket type with similar thread size. Resistors must remain in spark plug wire ends.

Coil Mount -The Stock coil mount may not be modified and may only be replaced with an INEX-approved coil mount.

Ignition Rotors - *The ignition rotor must be a Stock Yamaha FJ1200/XJR1200/XJR1250 part, or the rotor delivered with the "INEX approved" red ignition control box. The FZ09/MT09 rotor must remain Stock. No Aftermarket electronic ignition advancers are permitted*

Ignition Plates - *The ignition plate must be a Stock Yamaha FJ1200/XJR1200/XJR 1250 part or the plate delivered with the "INEX approved" red ignition control box. It may be slotted to advance the ignition timing of the engine. The ignition pickup cover is not mandatory. The FZ09/MT09 ignition plate must remain Stock.*

42. JAM NUTS: A minimum of one jam nut is required to be used with all radius rods and ball joints. One or two (minimum 1/4" maximum 7/16") jam nuts are permitted on the upper and lower ball joints.

43. LOWER CONTROL ARMS: *The lower control arms must remain Stock, within the Stock dimensions (12.5" x 16.25"), steel thickness, location, and configurations. Each measurement will have a tolerance of +/-1/8" (0.125").*

44. MANDATORY SERIES SPONSOR DECALS: The INEX, Hoosier Tire and Legend Cars decals must be prominently displayed in the INEX-approved locations (both sides of the car) at all INEX Events. Driver's not displaying the proper decals will not be eligible for awards, prizes, etc. including those offered at year-end and may be prevented from competing at certain Events.

45. MIRRORS: A Car may have a mirror for rear vision mounted within the driver's compartment or outside the doors. The type of mirror(s) shall be the choice of each individual Driver. Some Tracks may prohibit the use of mirrors.

46. MUFFLERS: INEX-approved USLCI Stock S & S, or Borla mufflers are MANDATORY for use with the Yamaha 1200 + 1250. *The ProFab muffler is mandatory for use with Yamaha FZ09/MT09.* The Muffler must remain Stock and may not be internally modified (turning tip away from car is permitted). INEX may monitor the decibel levels produced by the mufflers.

* The use of the USLCI "long" exhaust / muffler system is permitted and may be required by some racetracks.

47. NERF BARS: *The nerf bars must remain within the Stock dimensions, steel thickness, location, and configurations and may not be reinforced.* Nerf bars are not permitted to hold ballast. No other nerf bars are permitted.

Legends Right & Left Nerf Bars

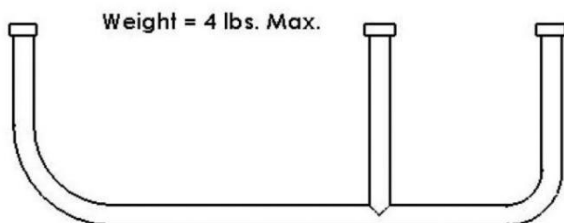

48. CAR IDENTIFICATION / NUMBERS: The car must have numbers that are a minimum height of 16" on both sides of the car and 18" on the roof (number facing towards the outside of the track). The car number (minimum 3" high) must be on the right front fender. If two cars show up at a track with the same number, the Race Director will determine number assignment. **The size, color and style of numbers must be adequate to permit prompt identification by Track Officials.** Numbers must not slant more than 30 degrees from vertical. Foil and reflective numbers will not be permitted. Violation of the above number rules will not be reason for Disqualification. However, if the above number rules are not followed, a car may not be scored. **Divisional Decals - (MANDATORY)** Each car must have a divisional decal ("P" for Pro, "M" for Masters or "S" for Semi-Pro, "Y" for Young Lions) on the left front fender & on the either rear fender.

49. OIL ADDITIVES: Any competitor using any of the following additives in the engine oil will be penalized by INEX. The following additives are not permitted for use at INEX Events: hydrazine, toluene, dinitrotoluene, dioxane, propylene oxide, nitropropane or any additional additives determined by INEX Technical Director to be hazardous.

50. OIL CATCH CAN: An oil catch can (maximum 1-quart capacity) may be used. It must be securely fastened and remain within the engine compartment. It may only be routed to by a hose from the Stock crankcase breather opening or the oil fill cap.

51. 1200 / 1250 OIL COOLERS & LINES: Only "Air" Oil coolers permitted (no dry ice or other type systems permitted). All oil cooling systems (including

lines) must be mounted in the engine compartment. Oil coolers may not be mounted below the bottom of the front bumper. More than one oil cooler is permitted. Oil cooler fans are permitted. Push-lock oil line fittings are permitted. Aftermarket oil coolers are permitted.

Oil Cooler / Radiator Scoops -Oil cooler / Radiator air scoops (with a maximum wall thickness of 1/8" sheet metal) must fit completely between frame rails and may not extend below or attach to the front bumper.

1200 / 1250 Overhead Oiling Systems -
Aftermarket overhead oiling systems for the camshafts are permitted.

52. OIL CRANKCASE BREATHER: The only locations that the Yamaha 1200 + 1250 crankcase may have a breather are under the carburetors at the Stock outlet or in the oil fill cap. *The FZ09 crankcase breather must remain in its Stock location.* The crankcase breather may not be evacuated through the exhaust pipe (header). There may not be any additional breather holes for the crankcase. Breathers and hoses must remain within the engine compartment. Baffles used in the hoses are permitted.

53. 1200 / 1250 OIL FILTER, REMOTE: Remote oil filters are permitted to be used on Yamaha 1200 + 1250 engines mounted in the engine compartment only. Inside or outside mounting of the remote oil filter to the frame rail is permitted. The remote oil filter must be located where it cannot be easily damaged in the event of an accident. Remote oil filter may not be mounted below the bottom of the front bumper. Filter must have a hose clamp around it, safely wired to the mount (to prevent it from backing off). Remote oil filter is NOT permitted on the Yamaha FZ09 engine.

54. PICK-UP POINTS & SPACERS: Modifications of the frame pick-up points, rear end pick-up points or spindle pick-up points are not permitted.

Spacers: A maximum 3/4" wide spacer may be used on any 1/2" suspension bolts. The space between the pickup points (when spacers are used on these 1/2" suspension bolts) cannot be more than 3/4".

55. RACK & PINION STEERING: *Only the rack & pinion steering box as delivered new by and stamped 600 Racing, INEX (or Mid-State Machine)*

is permitted. A Stiletto-brand or unmarked rack & pinion steering box is not permitted. The rack and pinion mounting plate measures 3 7/8" to 4" from the bottom of the frame rail to the top of the mounting plate (see diagram on page 60). A 4"x 4" x 1/8" plate will be allowed to be bolted (not welded) under the steering rack mounting plate. This will be a 4"x 4" x 1/8" plate with three holes using the steering rack studs to secure it. A 1/4" thick steering rack plate is permitted (as delivered by USLCl).

56. RADIOS & WIRING HARNESS: Two-way radios (UHF receiving device capable of monitoring Race Director audio as a priority communication over any two-way communication from the Race team only) are permitted but not required. All frequency transmissions must be UHF analog only. Encryption or scrambling of the signal is not allowed. Frequencies must be made available to INEX upon request. The only two types of communication that are allowed is a Raceceiver (that is controlled by the Race Director) and/or the UHF radio system as described above. Cell phones or any other source of communication that connects the Driver to any outside source is not permitted. (E.I.R.I.)

Two-way radios may be prohibited by some tracks, promoters or series.

57. RADIUS RODS/PANHARD BAR: *The aluminum Radius Rods and Panhard bar must remain within the Stock dimensions (Radius Rods 6"-6.5", 11.0" or 12.0" in length / Panhard bar -23.5" in length), thickness, location, and configurations. Each length measurement will have a tolerance of +/-1/8" (0.125"). The 11.0" and 12.0" rods may be interchanged anywhere on the car if the car still meets all other specifications. Steel radius rods or Panhard bars are not permitted.*

58. REAR AXLES: *The long and the short rear axles must remain Stock, within the Stock dimensions, steel thickness, location and configurations and may not be reinforced.*

Legends Axles

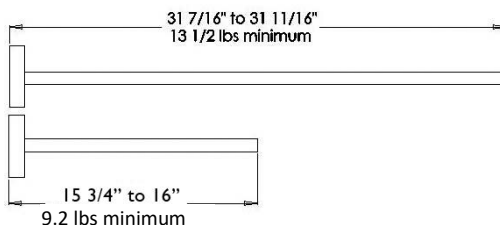

59. REAR END: Only 10 bolt pattern/wide flange (5/8") Toyota, locked-steel rear ends are permitted. All rear end components, to include the housing and pick-up points must meet the specifications of the Stock components. The rear end must be locked (all spider gears welded or steel spool of a minimum 6.0 pounds, 5.25 pounds for a 2:50 or 2.93 spool only). Limited slip differentials, Aftermarket differentials, quick change rear ends, floaters, homemade or otherwise are not permitted. "Tumbling, polishing, sanding, etc. of the ring & pinion or any internal parts of the rear end is not permitted. Coatings / finishes must remain stock (as delivered by US Legend Cars). Only OEM bearings are permitted. No hemispheric, ceramic coated or similar type bearings are permitted. No spacers are permitted between the backing plate and bearings. Axle tube material must be 3" O.D. and .120" wall thickness. "Double shear" rear end housing is available through USLCI. (Competitors can up-grade to the Stock USLCI "Double shear" specifications). Axle bearing flanges are square to the center line of the rear end housing.

Legends Rear End Housing

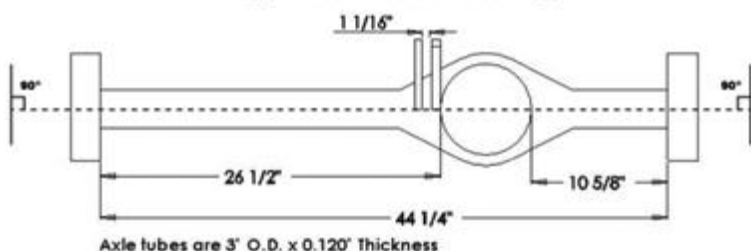

60. RIDE HEIGHT: A car must maintain 3 1/2" (minimum) height, between the bottom of the frame rails (not the weld) and the surface.

NOTE: This measurement is to be checked without the Driver in the car, as Raced, without lifting of the car in any manner. The inspection "location or spot" used to check ride height is determined by the INEX Technical Inspector.

61. RUNNING BOARDS: The running boards must remain within the Stock dimensions, steel thickness, location and configurations and may not be reinforced in any way.

62. SHEET METAL (Rear Deck & Dash): The minimum thickness of the steel sheet metal is .036". The rear deck sheet metal (including the package tray behind the Driver) may not be removed or altered in any way unless a fuel cell access hole is used. The fuel cell access hole must always be covered with a sheet metal plate and secured while the car is on the track.

Dash: The dash is mandatory. If dash is replaced it must weigh a minimum of 0.50 lbs. and cover both dash bars. Plastic or Lexan dash is permitted. A carbon fiber dash is not permitted. If extended switches are needed (for smaller drivers), they will need to be located on the driveshaft tunnel (by the shifter).

63. SHOCKS: *Legend cars must use INEX logo stamped, Legends, Bilstein shocks or INEX approved AFCO Legends shocks (with the AFCO / INEX tamper evident sticker sealing the cap).* These shocks must be run in sets. Bilstein & AFCO shocks are not permitted to be mixed. Shock numbers must be made visible at the request of an INEX Technical Inspector. Shocks may be turned upside down. The upper part of the rear shock may be mounted inside or outside of the frame. Shock bumpers are permitted (maximum 1/4" tall, "un-compressed"). *Modifying / altering the shock or shock fluid or internal components is not permitted.* Competing with a modified or altered shock(s) will result in suspension of the driver.

Shock Tower



Legends Shock Tower

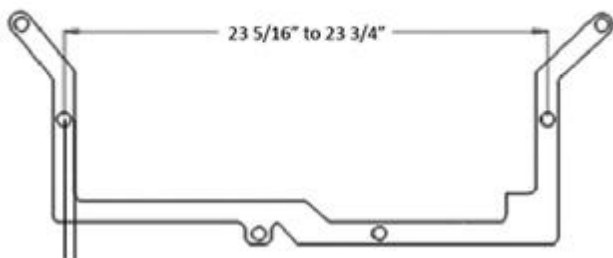

64. SHIFTER AND SHIFT LINKAGE: *Shifter linkage must be Stock.* Maximum height of the shifter handle is 15" as measured from the top of the driveshaft tunnel to the top of the shifter handle. The long shifter can be steel or aluminum.

65. SPINDLES: *The Aluminum spindles (and the spindle pick-up points) must remain Stock, within the Stock dimensions, thickness, location, and configurations.* Repairing a broken or cracked

aluminum spindle is not permitted.

66. SPRINGS: All cars must use 10" or 8" springs. Any spring weight combination and Aftermarket springs of Stock design are permitted (stock springs are the same outside diameter from top to bottom). Barrel springs, progressive springs or any springs that are not stock design are not allowed. Only one spring is permitted per shock. Spring rubbers are not permitted.

67. SPROCKET ADAPTERS: *The sprocket adapters must remain Stock, within the Stock dimensions, steel thickness, location, and configurations.* Set screws for the sprocket adapter nut are permitted. Modifying sprocket adapter in any manner is not permitted.

1250 engine = steel adapter (diagram below)

FZ09/MT09 engine = aluminum adapter

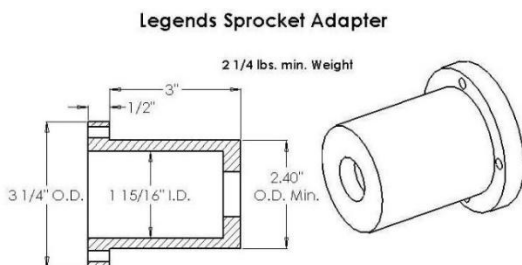

68. STEERING COLUMN: The steel steering shaft or steel steering column bracket may be modified for Driver comfort by altering the length of the shaft or by altering the steering column bracket that connects to the dash bracket. Aluminum "bolt on" steering brackets or aluminum Heim joint ends are NOT permitted. Bearings are not permitted to be used in mounting the steering shaft. Stock-style bushings and steel rod-ends must be used. Modifications for weight reduction are not permitted. A hose clamp or shaft collar is mandatory on the steering column in the engine compartment directly against the firewall. There can be no more than 1/4" gap between the clamp (collar) and the bushing. Modification of the driver's compartment roll cage is not permitted.

Steering Shaft - *Tubing used for steering shafts must be Stock and may not be reinforced in any manner.* Upgraded steering shaft joints are acceptable.

69. STEERING WHEEL: Larger or smaller steel or aluminum steering wheels are permitted. INEX-approved, quick release steering hub is mandatory.

70. TIRES:

ASPHALT SERIES TIRE RULES: *The tires must be USLCI marked Hoosier asphalt tires, as delivered by USLCI (for Competition on asphalt).*

Hoosier Tires may not be soaked, softened, “siped” (razor cuts), needled, grooved, or recapped. Tubes are allowed. Tire warmers and any other means of artificially warming tires are prohibited.

Hoosier Tire Hardness

Any Hoosier tire found under 61 points on the inspectors durometer (cold) will be confiscated & sent to INEX for lab testing and possible further penalties from suspension to expulsion.

Hoosier Tire Tread Depth

Tread depth (across the tire) must be no more than 1/32” different from side to side or outside to inside. The overall tread depth rule will be enforced using the wearbars in the tire. If a tire wears into the wearbar in two spots in a row (side by side or in the same groove), that tire will be considered illegal.

Dry Tire Rule –It is prohibited to use traction compounds or any substance that might alter the physical properties of a Hoosier tire as supplied by the manufacturer. Tire cleaners/shiners, tire softeners, track adhesives, brake fluid, diesel fuel, etc., will not be permitted on the tires. Any tire with an indication of use of these products on or inside them will be impounded for further testing. If Laboratory testing provides evidence of any of the above listed substances, that competitor will be subject to suspension.

DIRT SERIES TIRE RULES – *The tires must be USLCI marked Hoosier dirt tires, as delivered by USLCI. (for competition on dirt). Tires may not be soaked, softened, “siped” (razor cuts), grooved, needled or recapped. Tire warmers and any other means of warming tires are prohibited.*

Hoosier Dirt Tire Hardness

Any Hoosier Dirt Tire found under 58 points on the inspectors durometer (cold) will be confiscated & sent to INEX for lab testing and possible further penalties from suspension to expulsion.

Note: As of 1/1/2025, the USLCI marked Hoosier dirt tires will not be permitted to be grooved.

71. TRACTION CONTROL DEVICES: No electronic or computerized wheel spin/traction control device(s) is permitted installed in the car, whether operational or not. A car with these device(s) will subject the Driver to an INEX suspension.

72. UPPER CONTROL ARMS: *The upper control arms must remain Stock, within the Stock dimensions (4.25" +/-1/8" in length), steel thickness, location, and configurations and may not be altered in any manner.*

**Legends Upper Control Arm
Front Mounting Point**

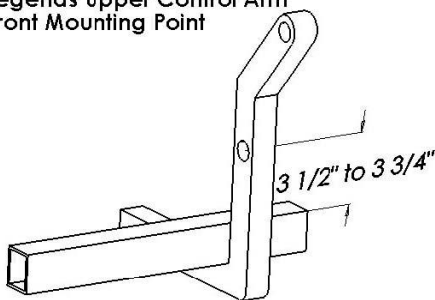

3 1/2' to 3 3/4' (from the top of the frame to the center of the pick-up point holes)

73. WEIGHT

The Legend Car weight minimums are as follows:

FZ09 engine with Hoosier tires (asphalt or rain) = 1230lbs. total / 585lbs. right side.

FZ09 engine with Hoosier dirt tires = 1250lbs. total / 615lbs. right side.

1200 or 1250 engine with Hoosier tires (asphalt or rain) = 1280lbs. total / 610lbs. right side.

1200 or 1250 engine with Hoosier dirt tires = 1300lbs. total / 640lbs. right side.

The above weights are measured with the driver in the car, as raced.

The rear weight percentage rule is, no greater than 52% without the driver for all engine / tire combinations.

NOTE: Competitors are not permitted to add fuel, fluids, or intentionally removed components after an Event to meet the weight requirements. It is the responsibility of each team to ensure that their car meets the weight requirements on the scales that are to be used by the INEX Official.

74. WEIGHT REDUCTION MEASURES: Lightening or modifying Stock components by shaving, milling, drilling or any other method is not permitted.

Components must remain the same material unless specified in this rulebook. Any component on a car that is used (other than what is specified) as a weight saving method is not permitted as determined by the INEX Technical Inspector in their sole judgement. Non-Stock aluminum or titanium components are in violation and will be confiscated. No weight reduction of the chassis or frame is permitted.

75. WHEELS: Any type of automotive steel wheel that has a 13" diameter, a 7" width and the offset of 3" to 3 1/4" from back rim edge to back of wheel center is permitted. The minimum Hoosier asphalt tire & wheel combination weight (using the Aero or Bassett "light" wheel) is 22.5 lbs. The minimum Hoosier asphalt tire & wheel combination weight (using the standard wheel) is 25.5 lbs. The minimum weight of a Hoosier dirt tire and standard wheel must be a minimum of 25.0 lbs. The minimum weight of an Aero or Bassett (INEX stamped and stickered ONLY) wheel and a Hoosier dirt tire must be a minimum of 22.0 lbs. All wheel weights must be secured with duct tape. Bleeder or relief valves are not permitted in the wheels. INEX approved (and marked) bead lock wheels will be allowed to be used on all four corners of the car for dirt racing.

76. WHEELBASE: Cars must compete with 72 3/4" to 73 1/4" wheelbase on either side.

Measuring wheelbase -The measurement will be taken with the front and rear tires on one side in line with each other. To determine this, the measuring tool or tape measure must touch three points. These points are the front of the rear tire sidewall and the front and rear of the front tire sidewall. The measurement is then taken from the front edge of the front wheel to the front edge of the rear wheel. The process is the same when measuring wheelbase on the opposite side.

77. TREAD WIDTH: The total overall tread width of the car (front and rear) may not exceed 61 inches maximum. The car must be able to roll freely through a 61 inch wide opening as Raced. Spacers on the wheels, axle, drums, etc. are not permitted.

78. REAR OFFSET: There must be a minimum of 6" between the inside edge of the rear brake drum and the outside rear frame rails (directly below the

centerline of the rear-end housing) on both sides. There must be a minimum of 6 1/2" between the rear brake disc and the outside rear frame rails (directly below the centerline of the rear-end housing) on both sides. Wheel, brake drum or axle spacers are not permitted.

Enforcement and Infraction Penalties of the Ride height, Wheelbase, Tread width and Rear offset

Rules 60, 76, 77, 78: After qualifying or after a Race, if a car is found to be in violation of the ride height, wheelbase, tread width or rear offset rules, and **only if requested by the Driver or Associate Member**, the Driver and/or Associate Member may have five (5) minutes to find the reason why the ride height, wheelbase, tread width or rear offset does not meet the rules. It is the Driver and/or Associate Members responsibility to find the reason (such as a bent part that would directly affect the infraction) before the car leaves the Technical Inspection area. It is not the INEX Technical Inspector's responsibility to find the reason. This process must all be completed within the Technical Inspection Area in the specified time. If no reason (such as damaged parts that would directly affect the infraction) can be found, this will result in a Disqualification.

79. WINDSHIELDS/SCREENS: A car must have either a screen or Lexan windshield in the front window area ("dirt style" rock screens are permitted). A sun visor is also permitted in the front window. Holes are permitted in the Lexan windshield.

ENGINE SPECIFICATION RULES XJ1250/FZ09/MT09 "SEALED"

The FZ09, MT09, XJ1250 & XJ1219 are sealed engines. Tampering, removing, or altering the engine seals will result in an immediate Disqualification, engine confiscation, loss of highest 5 Race finishing positions from International Points at season end, and a period of 12 months of probation. Additionally, the Driver, and/or car owner are subject to further penalties.

All components of the FZ09 & MT09 engines must remain Stock, location, and configuration. The FZ09 & MT09 engine must be installed exactly as the engine is installed at USLCl and include all factory Stock parts & pieces as shown in the installation instructions & video.

Competing with an engine that does not internally conform to the USLCI Engine Shop specifications will result in an immediate Disqualification, engine confiscation, loss of highest 5 Race finishing positions from International Points at season end, and a period of 12 months of probation. Additionally, the Driver, and/or car owner, are subject to further penalties.

INEX recommends that when purchasing an engine from a source other than USLCI, that it is inspected by the USLCI Engine Shop prior to Competition. All repairs requiring removing the seal(s) must be addressed by the USLCI Engine Shop.

1250 & 1219 ENGINE SPECIFICATIONS: The only modifications allowed to the factory sealed XJ engines are:

- A. Changing carburetor jets
- B. All Stock carburetor adjusters may be used
- C. Adjusting the valve shims
- D. Installing an Aftermarket clutch and spring of original design (no aluminum clutch plates).
- E. Upper head oilers, heavy-duty valve springs, "pinned" camshafts and steel sleeves are permitted if installed by an USCLI engine shop only.

Engines with clear plastic seals, green, blue, or silver (old style) seals will not be permitted to be used in any INEX Event.

ENGINE SPECIFICATION RULES FJ & XJ 1200

The unsealed engine must remain a factory-Stock Yamaha FJ1200/XJR1200 as delivered new through USCLI Engine Shop. Only those changes as described in the rulebook are permitted to be made to the FJ1200 and XJR1200. A Yamaha FJ1200/XJR1200 manufactured for other countries (Canada, England, etc.) or an FJ1100 may be used if it meets all the specifications of the USLCI Engine Shop.

If this rulebook does not specifically say that you can change/modify/add something, then you must consider that the change/modification/addition is illegal.

Any questions about the legality of a change/modification/addition not covered in this rulebook must be answered by INEX in writing and presented to the tech inspector upon request. If you have a

request for a change/modification/addition, please contact INEX before making the change/modification/addition.

Engine Type: Air cooled 4-Stroke gasoline

Carburetor: Bs36 X 4 Mikuni

Displacement: 1,188 cm³ (maximum 1,203 cm³ permitted)

Bore: 77.0 mm (3.032 in.) with a maximum .022 in. overbore permitted.

Stroke: 63.8 mm (2.512 in.)

Compression Ratio: 9.7:1 (maximum 10.0:1 permitted)

Starting System: Electric Starter

Cam Shaft:

Intake "A" 35.95 to 36.05 mm (1.415 to 1.419 in.)

Minimum limit 35.85 mm (1.411 in.) Intake "B" 28.25

to 28.35 mm (1.106 to 1.116 in.) Minimum limit 28.15

mm (1.106 in.) Exhaust "A" 35.95 to 36.05 mm

(1.415 to 1.419 in.) Minimum limit 35.85 mm (1.411

in.) Exhaust "B" 28.25 to 28.35 mm (1.106 to 1.116 in.)

Minimum limit 28.15 mm (1.106 in.)

DIAGRAM OF CAM SHAFT LOBE

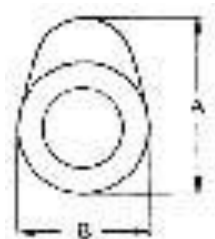

Cam Chain:

Type/# of lobes 79RH2015 (Silent Chain)/156 links

Adjustable method Automatic (Manual is permitted)

Valves:

Head Diameter: Intake: 28.9 to 29.1 mm (1.138 to

1.146 in.) Exhaust: 24.9 to 25.1 mm (0.980 to

0.988 in.) **Stem Outer Diameters:**

Intake: 5.475 to 5.490 mm (0.2156 to 0.2161 in.)

Minimum limit: 5.445 mm (0.2144 in.)

Exhaust: 5.460 to 5.475 mm (0.2150 to 0.2155 in.)

Minimum limit: 5.430 mm (0.2138 in.)

Valve Guide Inside Diameters:

Intake: 5.500 to 5.512 mm (0.2165 to 0.2170 in.)

Maximum limit: 5.550 mm (0.219 in.)

Exhaust: 5.500 to 5.512 mm (0.2165 to 0.2170 in.)

Maximum limit: 5.550 mm (0.2190 in.)

Transmission:

Type: Constant mesh, 5-speed

Gear Ratio: 1st -40/14 (2.857) 2nd -36/18 (2.000)

3rd -33/21 (1.571) 4th -31/24 (1.291) 5th -29/26

(1.115)

Legend Car Engines:

The only engines that can be used in Legend Cars at INEX Events are Yamaha's 1200 (unsealed), 1219 (sealed), 1250 (sealed), the FZ09 (sealed) & the MT09 (sealed).

The 1200 must meet the rules as outlined in the rulebook. The 1219 must remain sealed as a 1219. However, you can restore the 1219 back to a 1200 that meets the rules for a 1200 as outlined in the current rulebook (this engine will have a 1200 serial number). The 1250 must remain sealed and may not be restored to a 1200 (this engine will have a serial number with a P503E or a P506E prefix).

The 1250 engine and the FZ09/MT09 engine can only be raced as a sealed engine.

STOCK YAMAHA CAMSHAFT

STRESS RELIEVING THE CAMSHAFTS

INEX has approved polishing the shaft of the cam in these areas (for stress relieving purposes only).

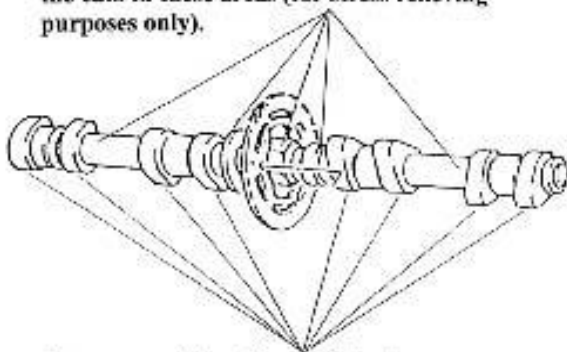

You may not alter the cam lobe in any way. (The sides of the cam lobe must remain untouched, with casting marks on them).

1. 1200 CAM SHAFT: The cam shaft must remain as Stock Yamaha FJ1200/XJR1200 as delivered new by USLCI. The cam shaft marking ("I" and "E") may not be removed. Stress relieving by machining or polishing on the radius next to the cam gear or on the shaft is permitted. Modifying any part of the lobes (lift, profile, duration, weight, etc.) is not permitted. Installation of a ¼" (I.D.) X ½" (O.D.) piece of 4130 aircraft steel the full length of the camshaft is permitted.

Note: This modification must be performed in a very specific manor, please contact USLCI Engine Shop for details.

2. 1200 CAM CHAIN: *The cam chain must remain as Stock Yamaha FJ1200/XJR1200 as delivered new by USLCI*

3. 1200 CAM CHAIN ADJUSTER: Aftermarket manual cam chain adjuster is permitted to be used on an unsealed engine.

4. 1200 CLUTCH: The clutch (plates and springs) may be replaced with any Aftermarket type of the same design (no aluminum clutch plates). Due to the rigors of road racing, a billet aluminum clutch basket will be allowed for road racing only. The basket, primary drive gear, shims and springs must weigh a minimum of 5.5 lbs.

5. 1200 CYLINDER HEAD: The original equipment cylinder head of an un-sealed engine must remain in unaltered "as cast" condition except for machining the gasket surface (no angle milling allowed). Valve seat inserts may be reworked or replaced with OEM or Aftermarket seats of original dimensions. The Stock I.D. at the bottom 1/16 of an inch is 0.990" for the intake port and 0.830" for the exhaust port. No port alterations of the intake or the exhaust below the seat are permitted. O-ringing the head gasket seal area is not permitted.

Combustion Chamber -Relief cuts for cubic centimeters balancing may not exceed the bore size.

Repairing a Cylinder Head - A combustion chamber may be repaired by welding and grinding back to the "Stock" specifications and configuration of the combustion chamber.

6. 1200 COMPRESSION RATIO: The compression ratio of an un-sealed engine may not exceed 10.0:1 (no tolerance) If the compression ratio is greater than 10.01:1, it will result in an immediate Disqualification and confiscation of all of the following parts including: the head, the valves, the head gasket, etc.) as well as the pistons and cylinder casings (including base gasket). Upon rebuilding, only the following are permitted: machining the piston domes and gasket surfaces of the cylinder head and/or cylinder casing.

7. 1200 CRANK SHAFT: *The crank shaft must remain as Stock FJ1200/XJR1200 as delivered new by USLCL.* Modifying the throw balances or weight of the crank is not permitted. Polishing the crankshaft is not permitted. Minimum crankshaft weight will be 27 pounds.

8. 1200 CRANKING COMPRESSION: The cranking compression of an un-sealed engine must be at or below 165 p.s.i. (at any temperature) on at least three (3) cylinders with the ignition off, the throttle wide open, and with the carburetors installed. Ten to

twelve revolutions of the engine will determine the total compression of a cylinder. Cam timing may be adjusted accordingly to meet the requirements of this rule by slotting the cam sprocket gear or substituting with an Aftermarket cam gear sprocket. INEX highly recommends that you have your engine set at 155 p.s.i. cranking compression instead of at 165 p.s.i. maximum to allow for variations between inspection gauges. There is no tolerance for engines over 165 p.s.i. The gauge used by the Technical Inspector is the "official gauge."

9. 1200 OIL PAN - *The Stock oil pan may not be altered, modified, or include any additions to alter the path of oil.*

10. 1200 OIL PUMP - The Stock oil pump may not be modified in any way. Relief valves may be shimmed.

11. 1200 PISTONS & RINGS: The cylinder bore of an un-sealed engine may not exceed 77.57 mm or 3.054" (maximum .022" overbore from Stock).

Cylinder Sleeves - Worn cylinder sleeves may be replaced with Aftermarket sleeves.

Pistons: Only Yamaha pistons (part #1TX 11631-00 and #1TX 11636-00) or forged Wiseco pistons (part #K1188, #L1195, #L1199 and #L1202) are permitted. The ring lances and lower part (skirts) of the piston may not be altered from the original in any manner. Gas-porting the pistons are not permitted. Wrist pin buttons may be used.

Rings: Only Yamaha rings (part #1TX 11610-00 and #1TX 11610-20) or Wiseco rings (part #21-3041X9 and #21-3051X6) are permitted. These rings may not be altered in any manner.

12. 1200 RODS: The rods in an un-sealed engine must remain as Stock FJ1200/XJR1200 as delivered new by USLCI. Rod bolts may be changed to any Aftermarket type. Only shot peening the rods is permitted (no polishing by any means is permitted). Weight balancing to the lightest unaltered rod is permitted. All dimensions must be Stock. XJ1250/XJ or XJR1300 connecting rods are not allowed in an un-sealed engine.

13. 1200 STROKE: *The stroke must remain Stock for the FJ1200/XJR1200 Yamaha as delivered new by USLCI.*

14. 1200 VALVES: Only Stock Yamaha FJ1200/XJR1200 valves are permitted. No modifications are permitted to the valves except for altering the number of angles of the seat and a maximum back cut width up to 0.200" is permitted from edge of the valve. Valve jobs are permitted. Only Stock valve lifter and adjuster shims may be used.

15. 1200 VALVE GUIDES: The valve guides must remain the same size, length, and location of the current Stock valve guides. The guides may not be altered in any manner. Shot peening of valve guides are not permitted. Brass Aftermarket valve guides of the same dimensions of Stock may be used.

16. 1200 VALVE SPRINGS: The valve springs may be replaced with Aftermarket magnetic steel springs. Only Stock steel valve spring retainers and clips/keepers are permitted. No titanium or other lightweight alloys are permitted.

17. 1200 TRANSMISSIONS: *The transmission and transmission gears must remain Stock Yamaha FJ1200/ XJR1200/XJR1250 (sealed) in the Stock configuration.* They may not be modified or lightened in any way. The transmission gears may be shimmed only for the purpose of proper engagement. Standard and Aftermarket shims may be utilized.

Note these rules are subject to change during the racing season. The Officials' interpretation of these rules is FINAL.



BRIGGS & STRATTON BANDOLERO CAR SPECIFICATION RULES

If this rulebook does not specifically say that you can change/modify/add something, then you must consider that the change/modification/addition is illegal.

Any questions about the legality of a change/modification/addition not covered in this rulebook must be submitted to and answered by INEX Technical Director in writing and presented to the INEX Technical Inspector upon request.

No equipment or Racecar will be considered as having been approved by reason of having passed through inspection unobserved. Regardless of a Bandolero Car passing prior inspections, compliance with all rules must be made at each post-Race inspection. No expressed or implied warranty of safety shall result from the technical inspection or approval.

FRAMES, BODY & SUSPENSION:

1. AERODYNAMICS: Spoilers, air dams or other aerodynamic devices other than Stock items are not permitted.

2. REAR AXLE: *The steel rear axle must remain within the Stock dimensions, steel thickness, location, and configurations and may not be reinforced in any way.* Any other type of Aftermarket rear axle, an axle modified for weight reduction or axles not in accordance with the above rule will not be permitted.

Bandolero Axle Tube Thickness

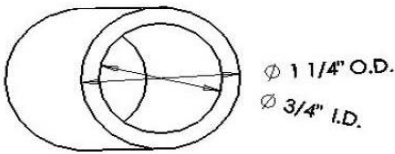

3. BALLAST: A maximum of two (2) blocks of lead are permitted on either the left or right sides of the car in the diagonal position. A maximum of two (2) 12" blocks or four (4) 6" blocks of lead are permitted on either the left or the right side of the Driver's seat for a total of eight (8) 12" blocks or a total of four (4) 12" & eight (8) 6" blocks of lead (Reference diagram on next page). There must be an equal number of ballast blocks, of equal weight on both the right & left sides of the car (the position of the blocks of lead must be a mirror image from left to right). For example; if there are two blocks of lead on the left side of the car, there must also be two blocks of lead on the right side of the car in the same position of equal amount and weight.

The only permitted sizes of ballast that may be used are as follows:

1. 12" long x 2-1/2" wide x 1-1/2" deep (approximately 20 lbs.)
2. 12" long x 2-1/2" wide x 3/4" deep (approximately 10 lbs.)
3. 6" long x 2 1/2" wide x 1 1/2" deep (approximately 10 lbs.)
4. 6" long x 2 1/2" wide x 3/4" deep (approximately 5 lbs.)
5. 12" long x 1 1/4" wide x 1 1/2" deep (approximately 10 lbs.)
6. 12" long x 1 1/4" wide x 3/4" deep (approximately 5 lbs.)

Mounting ballast -The blocks of lead must be bolted directly through the floor pan and chassis sub-frame (square tube) as shown in the diagram. The ballast block(s) must be secured with a minimum of two (2) 3/8" bolts, washers and locking nuts for each stack of lead. The blocks of lead may not be stacked higher than 3" from the square tube. The lead may not be encased in anyway. Ballast may not be added in any other location or by any other method, including steel shot or any other material in the frame rails, roll cage or bumpers. All mounting of the ballast must be approval by the INEX Technical Inspector.

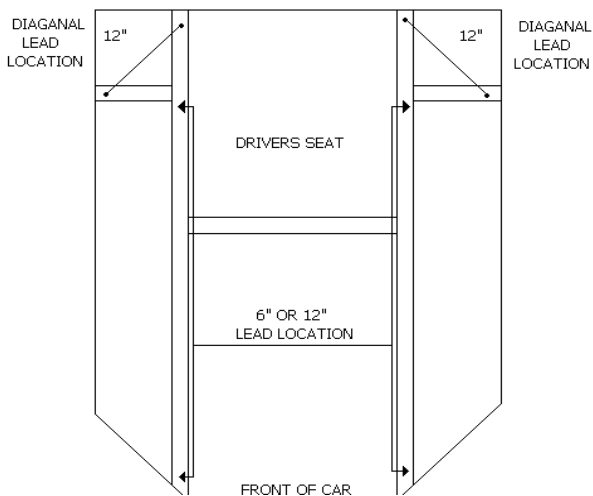

Any “Driver cooling system” equipment must be mounted on the right side of the car.

4. BATTERY: A single lead acid or gel cell battery (from 15lbs. – 25lbs.) or the US Legend Cars International, Feather – Lite, Lithium Battery or the ANTIGRAVITY battery (as delivered by US Legend Cars International) is permitted. A top post or side post battery may be used. The battery must remain in its Stock location and securely mounted. The original Stock battery bracket may not be altered in any manner. A battery box or terminal coverings is also highly recommended. A battery shut-off switch is optional.

5. BOLTS AND FASTENERS: Only equivalent Stock or upgraded steel fasteners and bolts may be used on the car. Fasteners may be drilled for safety wire, however weight saving modifications are not permitted. All bolts must be magnetic. Aluminum and titanium bolts are illegal. INEX Technical Inspectors must be able to identify the grade of bolt.

6. BRAKES: *The brake caliper and brake disc must remain Stock, within the Stock dimensions, steel thickness, location, and configurations.* Reference rule #30 (Scoops/ Ductwork) for information concerning brake ducts. Modifications to OEM or Aftermarket brake pads are not permitted.

Adjusting the brakes -The car is equipped with an adjustable push rod on the master cylinder. There are three (3) holes to choose from. The top hole provides the most leverage. The middle hole (factory setting) is for moderate leverage and the lower hole provides the least amount of leverage for braking force. A small spring may be installed on the clip

between the brake pads, and around to the bottom of the pads, to prevent them from rubbing the disk when not in use.

7. BRAKE LINES: Rubber or steel-braided brake lines are permitted. No brake lines may be disconnected or plugged at any time for Competition. Hard metal lines are not permitted. Brake lines may not run through the Driver's compartment.

8. BRAKE MASTER CYLINDER: *The brake master cylinder must remain Stock, within the Stock dimensions, location, and configurations.* No Aftermarket brake master cylinders are permitted.

9. BUMPERS: *The front and rear bumpers must remain within the Stock dimensions, steel thickness, location, and configurations and may not be reinforced in any manner except for the factory-delivered rear support bar.*

Attachment of the bumper – Bumper tabs must use a minimum of one bolt per tab securing the bumper. There must be a minimum of 1" from the end of the frame rail to the back of the bumper upright before each Race begins. Should the tab become bent during a Race, it must be fixed before the next time the car goes on the track to compete or practice. Tie-wraps, safety wire, duct tape, etc., are not permitted to be used to secure the front or rear bumpers or bumper tabs.

Bumper Tabs -*The bumper tabs must be Stock.* And must be .125" in thickness. Tabs with excessive weld will not be permitted.

Race Procedure Note: Bumpers are Mandatory
A car must compete with both bumpers that are not in contact with the track or considered in a dangerous position or condition by Track Officials at any time. If any of these conditions are not met, Track Officials may black flag the car.

NOTE: The INEX Technical Inspector does not have the authority to disqualify a Driver after the Race for a violation of this Race procedure.

Repairing a bumper During a Race – Bumpers are Mandatory throughout the race and must be bolted on in approved manner. Tie-wraps, safety wire, duct tape, etc., are not permitted to repair the bumpers. An INEX Technical Inspector will disqualify a Driver after a Race if the repaired bumper violates this rule.

10. CARBON FIBER: Carbon Fiber is not permitted to be used on a Bandolero Car.

11. CHAIN GUIDE: *Stock chain guides are mandatory for all cars.* The chain guide must attach to both sides of the sprocket on the axle.

12. CONTINGENCY SPONSOR DECALS:

Contingency sponsor decals are optional, however contingency decals are mandatory and /or use of the product to be eligible for posted awards sponsored by the contingency sponsor.

13. FIREWALL: An aluminum or steel sheet metal firewall is mandatory. Minimum thickness .036" Firewall must be installed as delivered new by USLCI.

14. FRAME: Absolutely no modifications of the frame (including the roll cage) will be permitted unless otherwise noted in this rulebook. Any other requested chassis modifications or unusual repairs are only permitted with a letter from INEX Technical Director (Letter must be presented at the track with the car).

Bandolero Rear Trailing Arm Mount

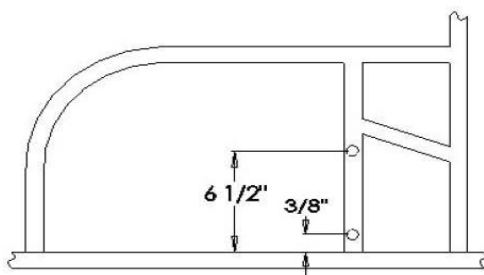

Serial number plate -Frame's competing must be manufactured by USLCI. A frame must carry the serial number assigned to that frame (the serial number can be found on the Vehicle Identification Number plate). This plate shall not be tampered with in any way.

Metal Fatigue -It is recommended to have the frame checked periodically by an expert for metal fatigue. Cracked or broken frames are prohibited from any INEX Competition.

Frame Replacement -If the chassis should become severely damaged, replacement frames must be purchased through USLCI or its authorized dealer network.

Frame Repair -Front and rear frame horns may be replaced if they are replaced with the exact material that it is replacing, and all pick-up points must

remain in the Stock locations as delivered from USLCI. The driver's compartment of the frame (roll bars, cross braces, etc.) may not be repaired or replaced if damaged (Reference rule Replacing a Frame).

Engine Location & Mounting *The engine must be bolted directly to the engine plate on the frame.* No spacers or other forms of mounting other than Stock will be permitted.

The INEX Technical Inspector reserves the right to disallow a repaired car from an INEX Competition that is not properly repaired.

Once a frame is repaired from its original form, INEX, USLCI and the Technical Inspector assume no liability for any injuries that may occur because of this repair regardless of the approval given to compete with that repaired frame.

15. GEAR SPROCKETS: Any Stock axle gear sprocket may be used (unless a "gear rule" is in place at a track).

16. GENERAL APPEARANCE OF THE CAR: Competitors must present a neat, clean, and Stock appearing car for any INEX Competition. Crash damaged cars must be repaired to the minimum technical standards before returning to Competition. An INEX Official may deny a car from competing if it does not meet the minimum acceptable standards as mentioned above. INEX Competition Director reserves the right to deny access in Competition because of a sponsorship, advertisement, paint scheme and/or lettering on a car not in good taste, in the spirit of keeping this a family sport.

17. IDENTIFICATION / CAR NUMBERS: The car must have numbers that are a minimum height of 14" on both sides of the car and on the roof (number facing towards the outside of the track). The car number (minimum 3" high) must be on the right side of the front of the car. If two cars show up at a track with the same number, the Race Director will determine number assignment. **The size, color and style of numbers must be adequate to permit prompt identification by Track Officials.** Numbers must not slant more than 30 degrees from vertical. Foil and reflective numbers will not be permitted. Violation of the above number rules will not be reason for Disqualification. However, if the above number rule is not followed, a car may not be scored.

Divisional Decals -Each car must have a divisional decal (“O” for Outlaws, or “B” for Bandits) on the left side of the front of the car. Violation of the above number rule will not be reason for Disqualification.

18. SERIES SPONSOR DECALS: Hoosier Tires, Briggs & Stratton, Bandolero Logo and INEX decals are mandatory and must be prominently displayed in the approved INEX locations at all INEX Events. Driver’s not displaying the proper decals will not be eligible for awards, prizes, etc. including those offered at year-end and may be prevented from competing at select Events.

19. HEIM JOINT ENDS: *Only magnetic steel Heims of similar dimensions as delivered new by USLCI permitted.*

NOTE: The Stock Heims joints are designed to bend/break and absorb energy under impact. Heims joints may be upgraded, however under impact, the upgraded Heims joints may not bend or break as quickly thereby transferring the impact-energy to the Driver and an injury may result (i.e. broken wrist from the transfer of energy).

20. JAM NUTS: At least one jam nut is required to be used with all Heim joint ends.

21. MIRRORS: Competitors may add a mirror for rear vision mounted within the driver’s compartment or outside the doors (as delivered by USLCI). The type of mirror(s) shall be the choice of each individual Driver. Mirrors may not be permitted at certain Tracks.

22. NERF BARS: The nerf bars must remain within the Stock dimensions, steel thickness, location and configurations as delivered new by USLCI and may not be reinforced in any way. Nerf bars are not permitted to hold ballast. No other types of nerf bars are permitted.

23. PEDALS: Competitors may change the location and length of gas and brake pedals within the drivers compartment if they remain mounted from the top bar as delivered from USLCI. Removing material from the original pedals is not permitted. Adding to the original pedals is permitted.

24. PICK-UP POINTS: Modifications of the frame pick-up points, rear axle pick-up points or spindle pick-up points are not permitted.

25. PLASTIC & FIBERGLASS BODY

COMPONENTS: *All plastic and fiberglass body components must remain within the Stock dimensions, thickness, location, and configurations and may not be reinforced or modified.*

Mounting of Components -Plastic and fiberglass body components must be firmly attached to every car in Competition. A car may be black flagged or denied entry to start a Race if any of the aforementioned items are not attached unless prior approval is given by the INEX Technical Inspector. Removal of un-damaged body components is not permitted.

Dashboard -The hump in the dashboard may be removed and replaced with a flat dashboard if the new dashboard is sturdy, strong, and properly mounted. The INEX Technical Inspector must approve this modification before Competition.

Rear Deck Lid - Louvered tail sections and kits will be permitted as delivered by USLCI.

Rear Tail Section – The opening in the rear tail section for the exhaust pipes / mufflers cannot be any larger than 3 ½" X 8".

Rear Bumper Cover – The opening in the rear bumper cover for the rear frame horns / bumper mounts cannot be any larger than 3" X 4".

26. RACK & PINION STEERING: *Only the rack & pinion steering box stamped "600" is permitted.*

27. RADIOS & WIRING HARNESS: Two-way radios (UHF receiving device capable of monitoring Race Director audio as a priority communication over any two-way communication from the Race team only) are permitted but not required. All frequency transmissions must be UHF analog only. Encryption or scrambling of the signal is not allowed. Frequencies must be made available to INEX upon request. The only two types of communication that are allowed is a Raceceiver (that is controlled by the Race Director) and/or the UHF radio system as described above. Cell phones or any other source of communication that connects the Driver to any outside source is not permitted. (E.I.R.I.) Two-way radios may be prohibited by some tracks, promoters or series.

28. RADIUS RODS/PANHARD BAR: *The radius rods and Panhard bar must remain within the Stock dimensions (radius rods –5.5", 7.0" or 8.25" in length / Panhard bar 11.0" in length), aluminum thickness, location, and configurations. Each length measurement will have a tolerance of +/-1/8" (0.125"). Steel radius rods or Panhard bars are not permitted.*

– **Bandolero Panhard Rod Mount**

The panhard rod mount must measure 2 7/8" to 3 1/8". To be measured from the top of the square tube of the chassis to the top of the mount (no spacers are allowed on the top of the mount).

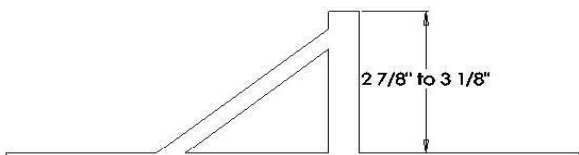

29. SCOOPS/DUCTWORK: A maximum of two scoops are permitted on the car. Only one scoop is permitted per side of the car. The scoop must be mounted approximately 14" forward from the center of the rear wheels. The scoop must measure approximately 8 1/2" up from the bottom edge of the body to the top of the scoop. A hose is permitted to be attached to the scoop to assist in the directing of airflow to the brakes or the engine. The hose must be attached to the end of the duct and must be mounted securely, directing air to the brake caliper or the engine only. The permitted hose may not measure any larger than 3" in diameter. Fans may not be placed inside the hose or duct. Any Competitor caught directing air to any location other than the brakes or the engine will be disqualified. The scoop may be no larger than the scoop offered by USLCI. Competitors may not direct air to the air filter box or the carburetor in any manner. Securing the hose to the side of the engine shroud is permitted.

30. SHEET METAL: The minimum thickness of the aluminum or steel sheet metal is .036". The sheet metal may not be removed or altered in any way. The fuel cell access hole must always be secured when the car is on the track.

31. SHOCKS: *Cars must use INEX-logo stamped, Bandolero Bilstein shocks or INEX approved AFKO Bandolero shocks (with the AFKO / INEX tamper evident sticker sealing the cap) as delivered by US Legend Cars. These shocks must be run in pairs. Bilstein and AFKO shocks are not permitted to be mixed. Changing or altering the shock or fluid inside the shock is not permitted. Altering or tampering with*

the shock(s) or competing with the same will result in suspension of the driver. Shock bumpers are permitted (maximum 1/4" tall, "un-compressed"). Shock numbers must be made visible at the request of an INEX Technical Inspector.

Shock Mount Spacers – Spacers up to 1/2" wide maximum will be permitted to be used on the 1/2" shock mounting bolts.

32. SPRINGS: A car must use 8" length springs. Any spring weight combination and Aftermarket springs of Stock design are acceptable (stock springs are the same outside diameter from top to bottom). Barrel springs, progressive springs or any springs that are not stock design are not allowed. Only one spring is permitted per shock. Spring rubbers are not permitted.

33. SPROCKET AND BRAKE ROTOR HUBS: *Must remain Stock.*

34. SPINDLES: *The spindles (and pick-up points) must remain Stock, within the Stock dimensions, steel thickness, location, and configurations.*

Bandolero Spindle

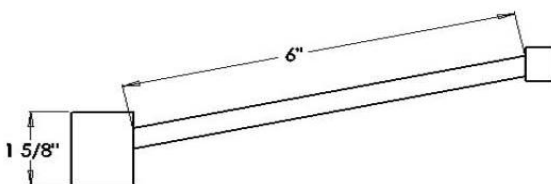

Lower Control Arms - Lower control arms must remain in the Stock location and configuration (no spacers between frame and control arm).

Bandolero Lower Control Arm Mount

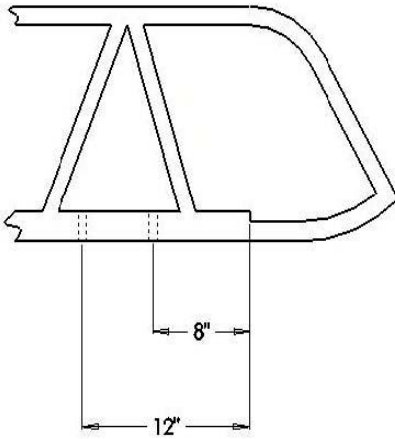

Bandolero Lower Control Arm

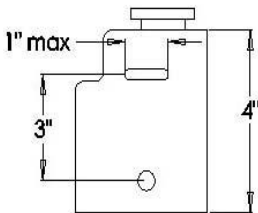
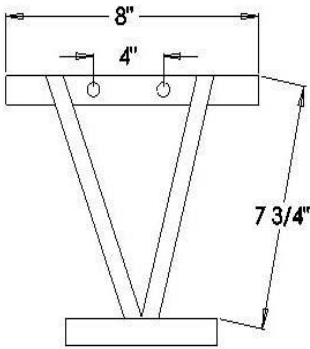

35. STEERING COLUMN: The steering shaft or steering column bracket may be modified for Driver comfort or safety by altering the length of the shaft or by altering the steering column bracket that connects to the dash. Weight reduction is not permitted (No aluminum brackets).

Steering Quickeners -Steering quickeners are not permitted.

Steering Shafts - *Tubing used for steering shafts must remain Stock and may not be reinforced in any way.*

36. STEERING WHEEL: Larger or smaller, steel or aluminum, steering wheels are allowed. Properly working, INEX approved quick release steering hubs are mandatory.

37. TIRES: *The Bandolero tires must be Bandolero Edition Hoosier tires as delivered by USLCI.*

Tires may not be soaked, softened, "siped" (Razor cut), needled, grooved, or recapped. Tire warmers and any other means of artificially warming tires are prohibited.

Hoosier Tire Hardness

The minimum hardness (cold) of the Bandolero Hoosier tire is 62 points on the inspectors durometer (any tire found under this number will be confiscated & sent to INEX for lab testing and possible further penalties).

Hoosier Tire Tread Depth

The minimum tread depth will be measured using the tread depth indicator holes in the face of the tread. If a tire wears flush with these tread depth indicator holes in two spots in a row (side by side or around the tire), that tire will be considered illegal. The tread depth (across the tire) must be no more than 1/32" different from side to side or outside to inside.

Hoosier Tire Dry Tire Rule -It is prohibited to use traction compounds or any substance that might alter the physical properties of a tire as supplied by the manufacturer. Tire cleaners/shiners, tire softeners, track adhesives, brake fluid, diesel fuel, etc., will not be permitted on the tires.

Any tires with signs of these products on or inside them will be impounded for further testing. If lab testing provides evidence of any of the above listed substances, that competitor will be subject to suspension.

38. TREADWIDTH: The total overall tread width of the car (front and rear) may not exceed 48 inches maximum. The car must be able to roll freely through a 48-inch-wide opening as Raced.

Rear Offset: There must be a minimum of 2" between the rear frame rails and the nearest rim edge of the rear wheel on both sides of the car. Wheel spacers are not permitted.

39. TRACTION CONTROL DEVICES: No electronic or computerized wheel spin/traction control devices are permitted in the car, operational or not. A Driver having these devices will be subject to INEX suspension.

40. WHEELS: *Wheels must remain Stock.* And must have the Bandolero or INEX logo engraved in the wheel. The original wheels and the new “GPS”, black wheels are both legal for use in INEX sanctioned competition.

The minimum weight of the Hoosier tire and wheel is 10 pounds (without additional steel or lead wheel weights).

Bleeder or relief valves are not permitted.

41. WHEELBASE: Cars must compete with a 70” to 70 1/2” wheelbase on either side.

Measuring wheelbase -The measurement will be taken with the front and rear tires on one side in line with each other. To determine this, the measuring tool or tape measure must touch three points. These points are the front of the rear tire sidewall and the front and rear of the front tire sidewall. The measurement is then taken from the front edge of the front wheel to the front edge of the rear wheel. The process is the same when measuring wheelbase on the opposite side of the car.

42. WHEELBEARINGS: *Wheel bearings must remain within the Stock dimensions, thickness, location, and configurations and may not be modified.* Ceramic coated wheel bearings are not permitted.

43. WHEEL HUBS: Front and rear wheel hubs must remain stock as delivered by US Legend Cars International. Lug studs must remain stock as delivered by US Legend Cars International (1/2 – 20 X 1 3/4” socket head cap bolt).

44. WEIGHT: 750 lbs. minimum car and Driver weight (as Raced). Competitors will not be permitted to add fuel, fluids, or intentionally removed components after an event to meet minimum weight. It is the responsibility of each team to ensure that their car meets the weight requirements on the scales that are to be used by the INEX Official.

45. WEIGHT SAVING MEASURES: Lightening or modifying Stock components by shaving, milling, drilling or any other method is not permitted. Any item on a car that is used (other than what is

mentioned in the rules) as a weight saving method is considered illegal as determined by the INEX Technical Inspector in their sole judgement. Non-Stock aluminum or titanium components are considered illegal and will be confiscated immediately. Components must remain the same material unless specified in the rulebook.

Enforcement and Infraction Penalties of the Wheelbase, Rear offset and Tread width Rules:

After qualifying or after a Race, if a car is found to be in violation of the wheelbase, rear offset or tread width rule, and **only if requested by the Driver or Associate Member**, the Driver and/or Associate Member may have five (5) minutes to find the reason why the wheelbase, rear offset or tread width does not meet the rules. It is the Driver and/or Associate Members responsibility to find the reason (such as a bent part that would directly affect the infraction) before the car leaves the Technical Inspection area. It is not the INEX Technical Inspector's responsibility to find the reason. This process must all be completed within the Technical Inspection Area in the specified time. If no reason (such as damaged parts that would directly affect the infraction) can be found, this will result in an immediate Disqualification.

46. WINDSHIELDS/SCREENS: Cars must have either a screen or Lexan windshield in the front window area.

47. WIRING: All Bandolero Car wiring harnesses must use the stock gauge wire as delivered by US Legend Cars International. (Wire connections, plugs, open wires or unused connectors are not permitted within reach of the driver).

Note these rules are subject to change during the racing season. The Officials' interpretation of these rules is FINAL.

ENGINE SPECIFICATION RULES

***The Briggs & Stratton Vanguard engine is a sealed engine. Tampering, removing, altering the engine seals will result in an immediate Disqualification, engine confiscation, loss of the highest 5 Race finishing positions from International Points at season end, and a period of 12 months of probation. Additionally, the Driver, and/or Associate Member are subject to further penalties.

Competing with an engine that does not internally conform to the USLCI Engine Shop specifications will result in an immediate Disqualification, engine confiscation, loss of the highest 5 Race finishing positions from International Points at season end, and a period of 12 months of probation. Additionally, the Driver, and/or Associate Member are subject to further penalties.

INEX recommends that when purchasing an engine or from a source other than, that the engine be inspected by USLCI Engine Shop prior to Competition. All repairs requiring removing the seal(s) must be addressed by the USLCI Engine Shop.

Bandolero Engines with clear plastic seals, green (old style) seals, blue (old style) seals or silver (old style) seals will not be permitted to be used in any INEX Event.

If this rulebook does not specifically say that you can change/ modify/add something, then you must consider that the change/ modification/addition is illegal.

Any questions about the legality of a change/modification/addition not covered in this rulebook must be answered by INEX in writing and presented to the INEX Technical Inspector upon request. If you have a request for a change/modification/addition, please contact INEX Technical Director before making the change/modification/addition.

1. AIR FILTER: Only the Stock air filter is permitted as delivered by US Legend Cars International. Air filters may not have the element removed, cut, or tampered with to increase or restrict airflow in any manner. Air filters may not be soaked in any substance. *The foam pre-filter must remain in its Stock location and configuration and may not be*

altered or folded in any manner. The Air filter “hold down” nut must be tight & may be taped to secure it.

2. CARBURETOR: *The carburetor must remain Stock.* Only the fuel (removable main jets) jets may be drilled for size or replaced with OEM or Aftermarket jets.

The minimum main fuel jet size is as follows:

OPEN ENGINE

Right fuel jet = 110 / .0430”

Left fuel jet = 105 / .0405”

RED PLATE ENGINE

Both fuel jets = 112.5 / .0440”

BLUE PLATE ENGINE

Both fuel jets = 117.5 / .0465”

These fuel jet sizes are minimums. If a Bandolero carburetor is found with fuel jets smaller than listed for each engine configuration, that driver will be disqualified.

All Stock adjusters may be used. *Air jets (and snake eye jets) must stay Stock.* No Allen head jets, no drilling of jets allowed. Modifications or components to increase or restrict air flow or fuel flow (such as velocity stacks, heat deflector shields, internal modifications, etc., not listed above) are not permitted. No drilling or grinding is allowed anywhere on the carburetor. Modifying the intake casting is not permitted. Modifying the main fuel jets is not permitted (other than drilling for size). Modifying the Stock gasket(s) is not permitted. Modifying the Stock butterfly or choke plate is not permitted. Drilling or modifying the float bowl is not permitted.

* Engines running without a restrictor plate, must use the “INEX” aluminum carburetor spacer as delivered by USLCI. Engines running a restrictor plate, must use the plastic Briggs & Stratton carburetor spacer un-cut as delivered by USLCI.

Fuel Pump Vacuum Line -It is permitted for the rocker arm covers to be swapped so that the fuel pump vacuum is drawn from the left rear rocker cover. Using rocker arm covers with breather hoses in both covers is permitted. It is also permitted to drill and tap (3/16”) the intake turndown and install a fitting to run the vacuum line to this fitting. 36” is the maximum length for this vacuum line.

Restrictor Plate -*The restrictor plate must remain unaltered and must be installed in the Stock configuration as listed below.*

Bandolero Restrictor Plate Installation (only for use at Tracks that mandate the use of a restrictor plate)

- One gasket (Stock-un-cut) on top of the intake tube.
- One INEX restrictor plate (red or blue, whichever the track mandates) on top of the gasket (“INEX” identification up or down).
- One gasket (Stock-un-cut) on top of restrictor plate
- One plastic spacer (Stock-un-cut) on top of gasket
- One gasket (Stock-un-cut) on top of plastic spacer.
- Carburetor intake on top of gasket.

Any modification to increase airflow or bypass the restrictor plate may result in an INEX suspension.

SUGGESTED RESTRICTOR PLATE USAGE FOR THE BANDIT & OUTLAW BANDOLERO CLASS

Provided as a suggested manner of usage for tracks. The following recommendations are provided to the tracks as a template for competition. They are not mandated by INEX. Each track is responsible for mandating the proper restrictor plate determined by the size & speed of the track.

1/4 mile = No restrictor plate

3/8 mile = Red “INEX” restrictor plate

4/10 mile = Blue “INEX” restrictor plate

3. CLUTCH GEAR: *The NORAM clutch must remain in Stock configuration. The NORAM clutch gear(s) permitted for use are the 12, 13, 14 or 15 tooth. The only clutch springs allowed are Stock. No other modifications are permitted to the clutch (i.e. use of a non-slip clutch, welding of the clutch). The clutch shoes must remain unaltered except for regular maintenance by sanding the shoe face. The shoe must not be thinner than .180” to be measured at either end of the shoe (both ends must be .180” or greater). The Bully clutch must remain in Stock configuration. The Bully clutch gear(s) permitted for use are the 14, 15 or 16 tooth. Select Tracks may require a mandatory gear combination.*

4. ENGINE LOCATION AND MOUNTING: *The engine must be bolted directly to the engine plate on the frame. No spacers or other forms of mounting other than Stock will be permitted.*

5. ENGINE REBUILDING: Only USLCI Engine Shop can rebuild an engine. Contact USLCI Engine Shop at (704) 455-3896 to arrange for service.

6. ENGINE SERIAL NUMBER: An engine casing must have a serial number. Any engine casing

without a serial number will not be permitted in any INEX Events. This engine will be confiscated immediately and sent to the INEX Technical Director.

7. ENGINE SHROUD, COVERS & AIR BOX: The engine shroud / blower housing, sheet metal around the cylinder heads and the air box are to remain stock design, thickness, material & configuration and may not be modified or have any additions. The use of extra sheet metal, duct tape, etc. to change the airflow is not permitted. Changing the size of the holes in the bottom of the air box is not permitted. US Legends Engine Shop does tape over the .587" round hole in the bottom of the air box that lets air directly into the carburetor (bypassing the air filter). This .587" round hole can be taped over by all competitors.

8. EXHAUST SYSTEM: *The header must remain within the Stock dimensions, steel thickness, length, location, and configurations. 1/4" thick flanges are permitted. The internal components of the header may not be altered. Header wrapping (tape) is acceptable. Ceramic or baked on coatings are not permitted. Holes may not be drilled anywhere in the exhaust system.*

9. FUELCELL: *Only an INEX-approved fuel cell is permitted, and it must remain in its Stock location.*
Fuel Cap: Aftermarket Racing fuel caps are permitted. The Driver is responsible for securing the fuel cell cap before entering the track. The cap should fit snugly on the fuel cell.
Fuel Cell Vent: The fuel cell vent must remain Stock location and configuration.

Fuel Cooling Devices: Fuel cooling devices of any kind are not permitted on the car at any time.

10. FUEL FILTER: An aftermarket fuel filter may be used. Glass fuel filters are not permitted.

11. FUEL LINE: The fuel line may not be located or run through the driver's compartment. Rubber, steel braided, or Kevlar braided fuel lines are permitted.

12. FUEL PUMP: *The mechanical fuel pump must remain Stock.* Electric fuel pumps are not permitted.

13. FUEL SHUT-OFF VALVE: Aftermarket fuel shut-off valves are permitted and must be labeled on & off.

14. GAUGES: Analog gauges that record or display the following information only are permitted -RPM, oil pressure, oil temperature, and cylinder head temperature. Digital gauges are not permitted except for Longacre and Intercomp lap timers, Lapceivers (by RACEceiver) and Fastach Digital Tach (by SunDec, Corp.) as delivered by USLCl. Any digital gauges not available through USLCl are not legal for use at any INEX sanctioned event. If a car is found with a gauge that violates this rule during qualifying, heat races, B-main or the main event, the gauge will be confiscated and the car will be disqualified from the event it was used in. If the gauge is found during race day practice, the gauge will be confiscated. No other information may be recorded. Onboard telemetry systems are not permitted, whether operational or not. Gauges that record or display wheel spin, shock travel, exhaust temperature, throttle position or G-force are not allowed.

15. IGNITION SYSTEM: *The complete ignition/engine control system must be the original OEM parts.* Electronic throttle (traction) controls are not permitted.

Spark Plug Boots -*These components must be Stock parts.*

Spark Plugs -Any Aftermarket spark plug may be used.

16. MUFFLERS: *INEX-approved Stock mufflers are mandatory.* 3 screens are required.

17. OIL ADDITIVES: Any competitor caught using any of the following additives in the engine oil may be suspended from all INEX Events for a minimum of 60 days from the date of the infraction: hydrazine, toluene, dinitro toluene, dioxane, propylene oxide, nitropropane or any additional additives determined by INEX to be hazardous.

18. OIL CATCH CAN: Only one oil catch can (maximum 1-quart capacity) may be used. It must be securely fastened and remain within the engine compartment. The oil catch can only be vented by a hose from the Stock crankcase breather opening or the valve covers.

19. OIL CRANKCASE BREATHER: The oil crankcase breather may not be evacuated through the exhaust pipe (header). There may not be any additional breather holes for the crankcase (i.e. from the oil fill cap). It may only be vented by a hose from the Stock crankcase breather opening or the valve covers.

20. REV-LIMITER: A car must compete with a rev-limiter that is always operating properly. No quick electrical disconnects may be used when wiring the rev-limiter. *The rev limiter must remain Stock (maximum 5,600 rpm) and must be wired into the toggle switches.* No modifications are permitted to the rev-limiter. If the rev-limiter does not work due to improper wiring or bad connections, the Driver will be disqualified.

21. VALVE SPRINGS: The valve springs may be replaced with an INEX-approved Aftermarket steel springs. Only steel valve spring retainers and keepers are permitted. No titanium or other lightweight alloys are permitted. Adjusting the valves is permitted.

Note these rules are subject to change during the racing season. The Officials' interpretation of these rules is FINAL.

CODE OF CONDUCT & SOCIAL MEDIA POLICY:

INEX Members, Associate Members, and participants are expected to maintain professional and respectful behavior at all INEX events, whether in person or online. This standard of conduct includes, but is not limited to, the following:

- **Unsportsmanlike Conduct:** Engaging in behavior that is detrimental to the sport of Legend Car or Bandolero racing, either in person or online.
- **Unsafe or Unfair Actions:** Creating conditions or circumstances that are unsafe, unfair, or disruptive to the order of events, which constitutes a violation of INEX rules and regulations and may result in penalties.
- **Threats or Physical Assault:** Making threats or physically assaulting another participant, official or individual, whether in person or online. Physical violence violations may also be referred to local, state, or federal law enforcement authorities for prosecution.

Team and Guardian Responsibility

- INEX Members, and/or Associate Members are responsible for the behavior of their crew members or anyone associated with their team. Penalties imposed on the team may also extend to the driver (INEX Member) for misconduct by these individuals.
- For INEX Members under the age of 18, the designated Associate Member (typically a parent or guardian) assumes responsibility for the conduct of the driver, crew members, and anyone associated with the team. In such cases, penalties may be applied to both the driver and the Associate Member.

USLCI/INEX Social Media Policy

USLCI/INEX defines social media as any form of electronic communication or content sharing on the internet. This includes, but is not limited to, personal or third-party blogs, websites, social networking

platforms, and affinity sites. Examples of platforms covered under this policy include Facebook, Snapchat, X (formerly Twitter), Instagram, Threads, TikTok, YouTube, Reddit, and LinkedIn.

While social media forums may appear informal, individuals are solely responsible for the content they post or permit others to post on their behalf. Any social media activity that negatively impacts USLCI/INEX, its members, or affiliates—whether directly or indirectly—may result in disciplinary action, up to and including permanent exclusion from the series.

This policy applies to all USLCI/INEX Members, Associate Members, competitors, and officials. Competitors include drivers, entrants, family members, crew members, or any other individuals who are members or participants in USLCI/INEX-sanctioned events. Drivers are responsible for the actions of their crew. Officials include USLCI/INEX officers, employees, agents, representatives, and subcontractors. USLCI/INEX reserves the right to extend this policy to other members as deemed appropriate.

Guidelines for Social Media Conduct

1. Be Respectful

Avoid posting content that could be considered malicious, obscene, threatening, intimidating, harassing, or disparaging. Examples of unacceptable conduct include:

- Offensive posts intended to harm someone's reputation.
- Content contributing to a hostile environment based on race, gender, disability, religion, or other protected statuses.

2. Be Honest and Accurate

All posts are considered "on the record" and accessible to media, sponsors, fans, and partners, regardless of privacy settings. Posts may also be subject to discovery in legal matters.

- Avoid spreading rumors, speculation, or unofficial information regarding USLCI/INEX or its affiliates.
- Only share information after an official announcement has been made through authorized USLCI/INEX channels.

3. No Retaliation

Retaliatory actions against individuals who report or cooperate in policy investigations are strictly prohibited. Members who engage in retaliation will face disciplinary action, up to and including permanent exclusion from the series.

INEX Social Media Enforcement Policy

INEX is committed to maintaining a positive and professional online presence that aligns with our values and community standards. To ensure compliance with our Social Media Policy, INEX reserves the right to review and address any content posted on social media by its members.

If INEX, in its sole and absolute discretion, determines that any social media content violates the Social Media Policy or is otherwise deemed inappropriate, harmful, or contrary to INEX's values, INEX may require the member to remove or modify the content. Members must comply with such requests promptly and in good faith.

Non-compliance with this policy or failure to adhere to a content removal request may result in disciplinary action, up to and including suspension or termination of membership.

This enforcement policy applies to all forms of social media and digital communication platforms as outlined in INEX's Social Media

Policy. INEX retains the exclusive authority to interpret and enforce this policy as necessary.

Importance of Social Media

Social media plays a vital role in engaging fans, promoting the sport, and marketing USLCI/INEX, its drivers, teams, tracks, and sponsors. It provides a platform for direct interaction and connection with the racing community.

END NOTES:

1. ALWAYS HAVE FUN!!!

2. This is a professional organization and all participants are expected to conduct themselves accordingly. Drivers and/or Associate Members are responsible for the conduct of all persons or guests connected with the team. Let us remember that for our sport to grow, we need the support of the spectator. Please give all spectators the respect that you would like to receive from them. We want to promote OUR sport as "A Family Sport."

3. The Legend Cars, and Bandolero Cars are designed for racing use only! The car may NOT be modified for street use!

4. Carefully check your car before driving it. Particular attention should be paid to loose wheels, a loose seat, loose or damaged suspension parts and loose body panels and parts.

5. When first driving the car, it is highly recommended that you warm the engine up for at least three slow laps and gradually work up to speed. Following that, carefully sense any problems with the car. If you encounter a vibration of any kind, you should pull the car into the pits immediately and have it checked.

6. Our Drivers & Associate Members and members will always be "number one" to us; however, some very important people are contributing their time and money supporting Legend Cars and Bandolero Car racing. Track owners and Promoters work long, hard hours preparing for racing Events at their facilities. They spend money and time encouraging old and new fans to come out and watch you Race. PLEASE REMEMBER TO THANK THEM FOR GIVING YOU THE OPPORTUNITY TO RACE.

7. The Press is also very important to our sport. They are doing their part in keeping Grass Roots Racing in the spotlight. The Press is always looking for information. It is up to us (the Sanctioning body, the Promoters, and the Drivers/owners) to provide them with material related to our efforts.

8. We would also like to thank all of our series sponsors as well.